

SERVICE MANUAL

RE3 SG400



CSC
MOTORCYCLES

CSC MOTORCYCLES

ZS400 Motorcycle Maintenance Manual

First Edition (July 2019)

(Zongshen industrial group)

The copyright of this motorcycle maintenance manual is owned by Zongshen industrial group. The contents and pictures of this motorcycle maintenance manual are for reference only.

Preface

The motorcycle service manual details the motorcycle's basic structure, working principles, disassembly and maintenance, fault diagnosis and exclusion, etc. At the same time, it has also introduced the motorcycles technical specifications, performance parameters and maintenance and adjustment data. The manual is informative, illustrated and practical. It is hoped that this manual can provide support and guidance on the maintenance technology for the customers and aftersales staff.

The technical specifications, performance parameters and maintenance and adjustment data labeled in the manual are based on the latest status. Our company's subsequent improvements for this motorcycle model will be done without notice. If there is any difference between the manual and the improved product, please understand. We sincerely wish that you can tell us your ideas and suggestions about the design, manufacture or quality of the motorcycle, so that we can make improvements in time. Thanks for your support.

All the information, figures, data and performance indexes shown in the manual were the latest till the time the manual is printed. We have the authority to revise this manual without notice. Please understand. Please understand. Any part of this manual is copyrighted by Zongshen Industrial Group. No entities or individuals shall be allowed to reproduce the manual without the permission of our company. Otherwise, investigations will be conducted for criminal liability according to law.

This motorcycle manual takes the ZS400 model as an example to explain in detail the disassembly, installation, overhaul, fault phenomena and maintenance methods of this series of models. Due to the limited level of the editor, there may be some faults or careless omissions in the manual. We are looking forward to your criticism and corrections.

Chongqing Zongshen Automobile Industry Co., Ltd.

Address: Chaoyouchang, Banan District, Chongqing

Service hotline: 4007003088

www.zongshenmotor.com

For details, please click the website of our company: www.zongshenmotor.com

Editor July 2019

Symbols given in this Motorcycle Service Manual have the following meanings:

 Warning

It indicates a potential danger that may cause death or injury if any misoperation.

 Caution

It indicates a potential danger that may cause damages to the motorcycle if any misoperation.

 Suggestion

The most efficient service information is available for more simple maintenance and more understandable instructions.

Contents

Preface	2
Chapter I Overview	5
Section 1 Introduction of the Vehicle	5
Section 2 General Structure	6
Chapter II Maintenance Knowledge	8
Section 1 Maintenance Notes	8
Section 2 Basic Maintenance Knowledge	8
Section 3 Maintenance Adjustment Data	13
Chapter III Vehicle Parts	16
Section 1 Oil Supply System	16
Section 2 Cooling System	21
Section 3 EFI System	24
Section 4 Air Intake and Exhaust System	26
Section 5 Fuel Evaporation System	31
Section 6 Rear Transmission	34
Section 7 Frame and Subsidiary Organs	39
Section 8 Steering Mechanism	42
Section 9 Control Wire Rope	44
Section 10 Shock Absorbers	45
Section 11 Rear Fork	51
Section 12 Wheels	52
Section 13 Brake	59
Section 14 Instruments	65

Chapter IV Electricity and Gas Division	67
Section 1 Basic Knowledge.....	67
Section 2 Power Supply	69
Section 3 Control Section.....	73
Section 4 Electricity Consumption	78
Chapter V Motorcycle Fault Diagnosis Procedure	82
Section 1 Engine Fault Diagnosis Procedures	82
Section 2. Fault Diagnostic	91
Appendix: Electrical Schematic Diagram	102

Chapter I Overview

Section 1 Introduction of the Vehicle

ZS400 motorcycle is suitable for driving on road developed by our company. The exterior design of the motorcycle is novel and the operation is convenient. A single cylinder, four stroke and water cooled engine is adopted. The engine has the advantages of good cooling effect, strong power, good acceleration performance, etc. The frame is a tube welded frame with high strength and good rigidity. The brake is equipped with front and rear disc brakes, with stable braking performance, safety and reliability. The wheels are aluminum alloy wheels, which are beautiful, square and durable.

Fig. 1-1 Left side view of ZS400 complete vehicle

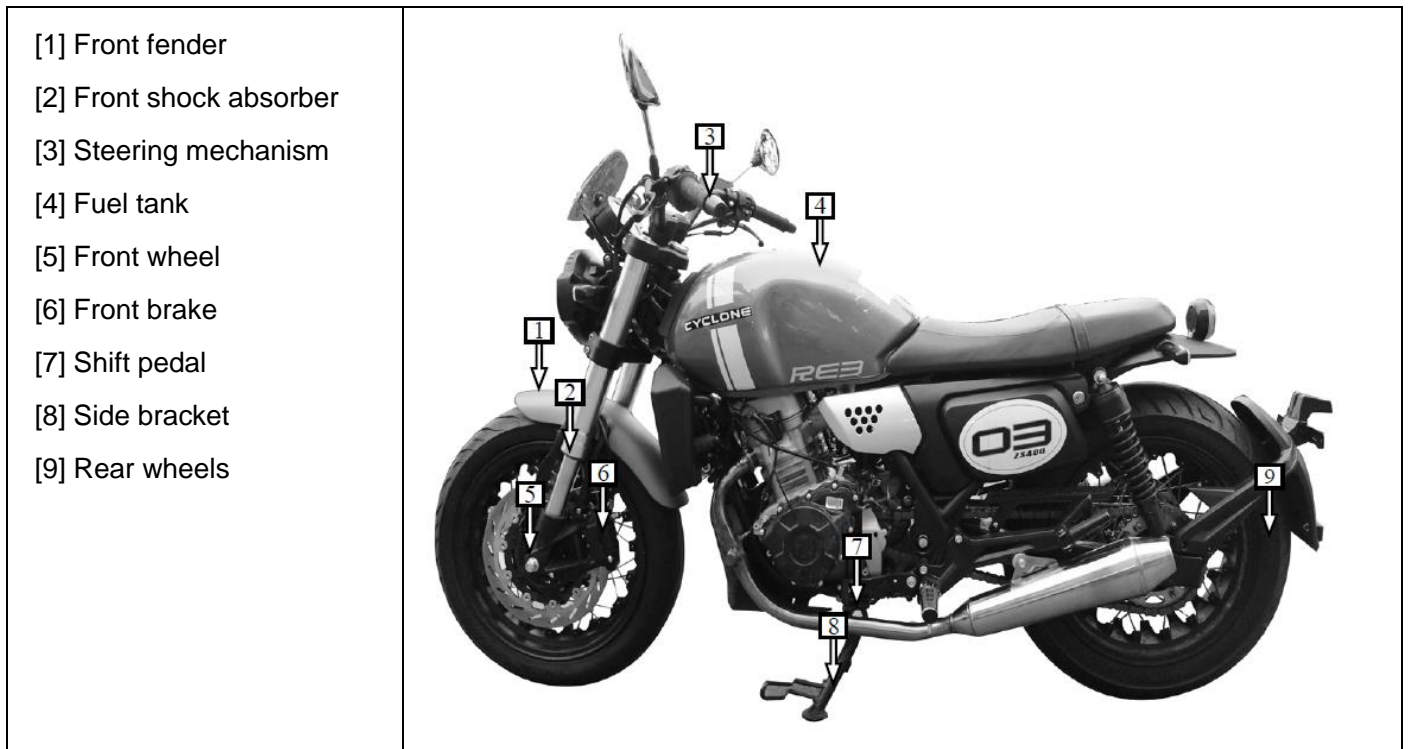
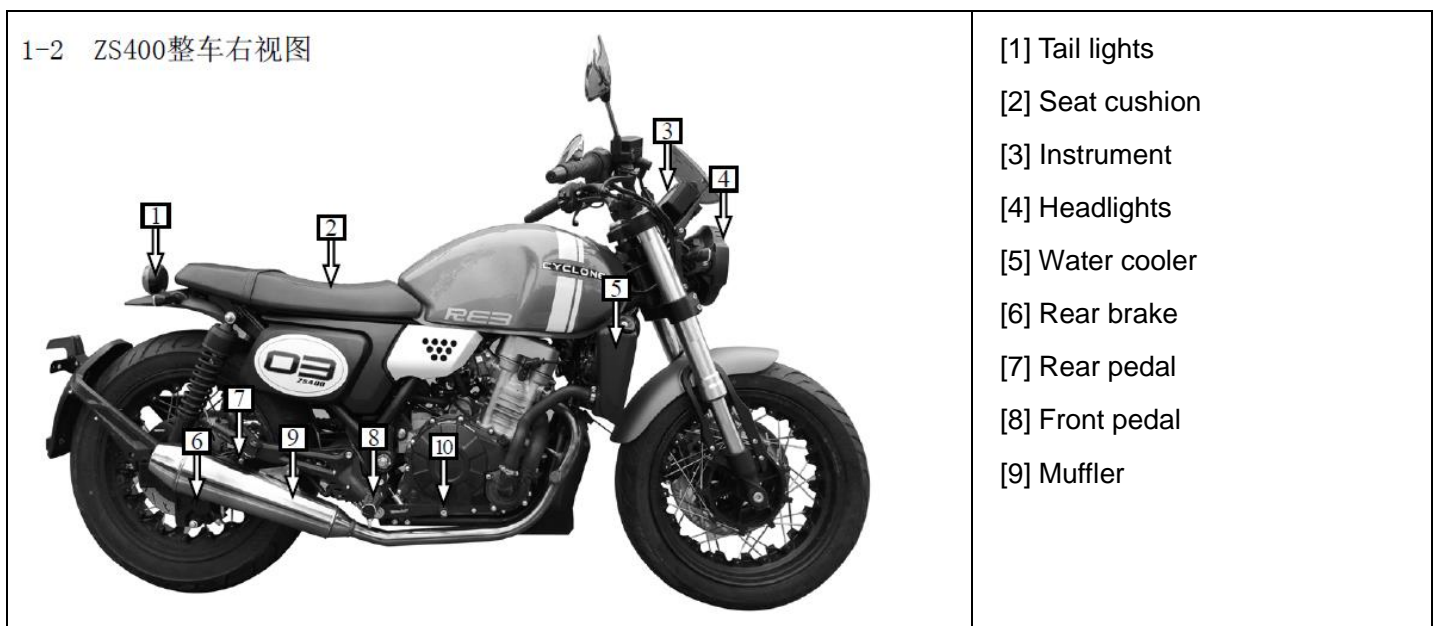

Fig. 1-2 Right side view of ZS400 complete vehicle



Section 2 General Structure

The motorcycle is mainly composed of walking system, steering and braking system, transmission system, oil supply system, electrical system and engine, as shown in Figure 1-5.

Figure 1-3 Overall structure of the complete motorcycle

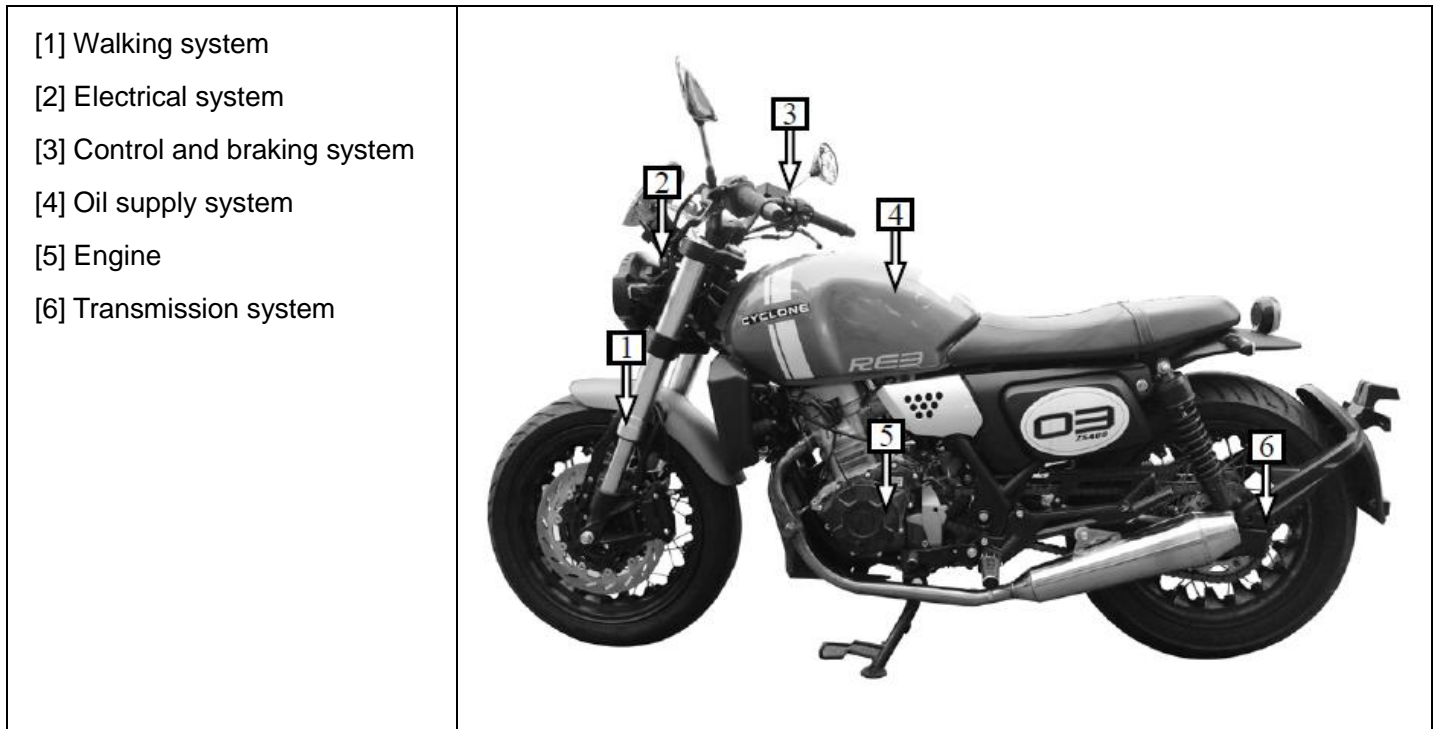

I. Walking system

The basic functions of the walking system:

- [1] Make motorcycles form a whole and support the quality of the whole car;
- [2] Receive the torque output by the transmission mechanism, and generate the traction force to drive the motorcycle through the adhesion between the driving wheel and the road surface;
- [3] Bear and transmit various external forces and moments formed by road surfaces acting on wheels;
- [4] Absorb or relieve the impact and vibration generated by motorcycle running.

The running system mainly consists of frame assembly, front and rear shock absorbers, front and rear wheels and other accessories.

II. Steering and braking system.

The main function of the control and braking system is to directly control the driving direction, driving speed, braking, lighting and signals, etc. to ensure the normal and safe driving of the motorcycle.

The control and braking system mainly includes steering device, braking device, operator handle connected with some devices, control switch, steel cable and other accessories.

III. Transmission system

The basic function of the transmission system is to change the torque or output rotation speed of the engine according to the road conditions and driving needs in a certain proportion, increase the torque or reduce the

rotation speed and then transmit it to the driving wheels to drive the motorcycle.

The transmission system mainly consists of starting device, clutch, transmission, rear transmission and other accessories.

[1] Starting device

The function of the starting device is to start the stationary engine and put it into self-running operation. Motorcycle starting device can be divided into pedal starting device and electric starting device.

[2] Clutch

The function of the clutch is to ensure reliable and gentle transmission or cutting off of the power output by the engine and to ensure a balanced start and This type of clutch is an automatic wet multi-plate clutch.

[3] Transmission

The function of the transmission is to change the rotational speed and driving torque of the motorcycle transmission system to ensure that the motorcycle has appropriate traction and speed to adapt to frequently changing driving conditions.

[4] Rear transmission device

The function of the rear transmission device is to further reduce the rotational speed and increase the torque of the power transmitted from the engine to the rear wheels, and then transmit it to the rear wheels to drive the motorcycle. The rear transmission device of this vehicle type is chain transmission.

IV. Oil supply system

The function of the oil supply system is to mix clean gasoline and air into a proper proportion of mixed gas according to the needs of different working conditions of the engine, and to supply it to the combustion chamber for combustion at a fixed time and in a fixed amount.

The oil feeding system mainly includes fuel tank, fuel pump, fuel injector, fuel filter and oil pipe, etc.

V. Electrical system

The function of the electrical system is to provide electric energy for the start-up and running of the whole vehicle and send out various acousto-optic signals to ensure safe and reliable running. Electrical system generally includes power supply part, power consumption part and control part.

[1] Power supply section

The power supply part mainly consists of a generator (magneto) and a storage battery. When the engine drives the generator to reach a certain rotating speed, the generator Besides being used by electrical equipment, the battery is also charged. The storage battery can convert the stored chemical energy into electric energy for starting, lighting and signal equipment.

[2] Power consumption part

The function of the power consumption part is to provide various acousto-optic signals to ensure driving safety, and at the same time to start the engine conveniently and quickly. The power consumption part mainly includes lighting signal device and electric starting device.

[3] Control part

The function of the control part is to ensure and coordinate the normal work of the power supply part and the power consumption part. The control part mainly consists of regulator, rectifier, starting relay, fuse (fuse), control switch and main cable.

VI. Engines

An engine is a power device that burns fuel in a cylinder and converts heat energy into mechanical energy, and is the power source of a motorcycle. The overall structure of the engine consists of cylinder head, cylinder block, crankcase body, piston group, crankshaft connecting bar group, air distribution mechanism, lubrication system, ignition system, cooling system, etc.

Chapter II Maintenance Knowledge

Section 1 Maintenance Notes

When a motorcycle breaks down, it must be repaired at the company's after-sales service maintenance station or a professional motorcycle maintenance station. At the same time, please refer to the contents of this manual for maintenance. As various parts of the motorcycle will be loosened and mechanically worn in different degrees during driving, if proper maintenance is not carried out, the power, economy, reliability and safety of the motorcycle will be reduced, and the service life of the motorcycle will also be shortened. Therefore, through correct maintenance, the faults can be eliminated in time, the service life of the motorcycle can be prolonged, and the maintenance cost can be reduced, so as to achieve the goal of safe driving of the motorcycle.

[1] When repairing motorcycles, please use original parts, accessories, lubricating oil and other auxiliary materials produced and manufactured by our company or recommended by our company. If parts and components that do not conform to the company's approval and recommendation are used, the power, reliability, stability and comfort of the motorcycle will be affected and the motorcycle may be damaged.

[2] When reassembling after disassembly, new gaskets, seals and cotter pins shall be replaced.

[3] When fastening bolts or nuts, they shall be carried out in diagonal cross sequence and tightened step by step in 2-3 times to reach the specified standard torque value.

[4] Do not use easy burning cleaning fluid when cleaning parts. Before assembly, lubricate the parts with lubricating oil or lubricating grease .

[5] After assembly, check whether all parts are installed correctly. Rotate, move, operate, check, etc. are required.

[6] When disassembling and assembling motorcycles, special maintenance tools and common maintenance tools shall be used for disassembly and assembly according to regulations.

[7] When repairing motorcycles, it should be carried out after flameout. If the maintenance work is carried out under the working condition of the engine, it must be carried out in a well-ventilated maintenance site, because the exhaust gas emitted by motorcycles contains toxic carbon monoxide (CO).

[8] Gasoline is flammable and explosive. Therefore, do not smoke, ignite or spark in maintenance areas.

[9] The electrolyte of storage battery contains sulfuric acid. If electrolyte is splashed on eyes, skin, clothes and other parts, clean them thoroughly with clean water,

[10] The storage battery will emit hydrogen, which is flammable and explosive. Therefore, smoking, ignition or spark are not allowed near the storage battery, especially

Section 2 Basic Maintenance Knowledge

I. Classification of maintenance operations

Maintenance can be divided into four categories: overhaul, intermediate repair, light repair and assembly repair according to the size of operation scope and the length of repair gap time.

[1] Heavy repair is a complete and comprehensive repair, which requires complete disassembly, cleaning, inspection and measurement, repair or replacement of parts, assembly and commissioning, etc. The motorcycle is restored to its original power, economy, reliability and safety performance indexes through overhaul.

[2] Medium repair is to repair and adjust the parts that affect the service performance. The hidden dangers can be eliminated through medium repair, the development of faults can be avoided, and a good dynamic state can be maintained.

[3] Minor repairs are operational repairs, mainly to eliminate temporary faults and local damages during operation.

[4] Assembly repair is a separate repair of an assembly or a component that affects the performance of the entire vehicle due to damage, wear, deformation, etc.

II. Repair technology

(I) Disassembly of motorcycle

Disassembly can also be called disintegration or decomposition. It is an important link in repair work. Whether the disassembly method is correct or not directly affects the quality and efficiency of repair work. If the parts are damaged or jammed due to improper disassembly, the repair scope will be expanded, the repair period will be delayed, and even the disassembly work will be stopped. The basic principle of disassembly is to proceed in the reverse order and direction of assembly, i.e. the parts assembled first and then disassembled, and the parts assembled later are disassembled first. Under normal circumstances, it can be carried out in the order of "first outside, then inside, first up, then down, first big, then small". When disassembling, it is especially important to pay attention to the storage environment and arrangement order of parts to prevent damage or confusion.

The sequence and method of disassembly are not absolute. The sequence and method of disassembly can be different depending on the vehicle type. It can be carried out with reference to the following methods of disassembly, installation and maintenance.

The basic principle for the disassembly of engine assembly and other component assemblies is the same as that of the whole vehicle. Due to the different structural types and characteristics of each component assembly, its disassembly sequence and method are also different. At the same time, because all the parts removed from the component assembly are parts, the storage environment and arrangement sequence are required to be higher.

The following points should be paid attention to when the whole vehicle and its component assemblies are disassembled:

[1] For parts with higher requirements for position matching, the matching marks shall be checked during disassembly. If the marks are not clear, the marks shall be re-made.

[2] When disassembling parts with interference fit, special tools shall be used. If without the special tool, it can be padded with wooden or soft metal tools, and then hammered with a rubber hammer in the right direction and at the appropriate position to prevent damage to parts.

[3] When removing the front and rear shock absorbing and front and rear wheel assemblies, the main frame should be firmly supported to prevent the frame from tipping over and hurting people or parts.

[4] The disassembled parts shall be placed in order according to the order of disassembly. Do not put painted parts, chrome plated parts and high precision parts directly on the ground.

[5] The removed nuts and bolts should be carefully stored, or they can be fitted to the original positions, but do not tighten them.

[6] All parts and components that need to be disassembled with special tools should be carefully operated in accordance with the regulations, and attention should be paid to uniform force and correct direction.

[7] When disassembling parts and components, appropriate tools should be adopted for each operation, and please pay attention to the size and direction of force to avoid damaging the parts.

[8] The dismounted brake shoes shall be stored separately, and contact with lubricating oil is strictly prohibited, otherwise, the brake will fail.

[9] When disassembly is difficult due to corrosion of threaded parts, soak gasoline there for several minutes before disassembly.

[10] When disassembling various gaskets and gaskets, care should be taken to prevent damage.

(II) Cleaning of Parts

After the parts are disassembled, most of them are adhered with oil stain or carbon deposit, which should be cleaned to facilitate maintenance and assembly. Gasoline, kerosene or cleaning liquid can be selected for cleaning. The cleaning method is determined according to the characteristics of the parts.

[1] Cleaning oil pollution

There are two methods of cleaning metal parts: cold washing and hot washing. Gasoline or kerosene is used as the cleaning agent, the parts are put in the cleaning agent, and the method of brushing with a brush is called cold washing. Using alkaline solution as cleaning agent, the machine parts are placed in the cleaning agent, heated to 79 ~ 90 and soaked for 10 ~ 15 min. After taking out, the machine parts are washed clean with clear water. This method is called hot washing method.

For cleaning nonmetallic parts, different cleaning methods should be adopted according to the different materials of the parts. Rubber parts should be cleaned with alcohol. Kerosene or gasoline is strictly prohibited to avoid rubber swelling and deterioration. The clutch plate and brake shoe friction plate should be scrubbed with gasoline, and it is forbidden to soak them in alkaline solution.

[2] Remove carbon deposit

The removal of carbon deposit on the machine parts can use either mechanical or chemical methods. Mechanical method is to use the bamboo scraper or shovel knife to remove first, then use gasoline to clean; The chemical method is to soak in cleaning solution, then remove with brush, and finally wash with hot water.

(III) Inspection of parts

After cleaning, the parts shall be inspected accordingly. The purpose of testing parts is to find out whether the part needs repair or scrap replacement. There are three kinds of inspection methods for parts: direct inspection, Detection inspection and exploratory inspection.

[1] Direct inspection

Direct examination does not require instruments and other tools, but only rely on human sensory organs to check and judge the technical status of parts. This method is simple and easy to operate and is widely used in maintenance.

[2] Detection inspection

Detection inspection is to determine the technical status of the parts by measuring the changes in size and geometry of the parts with gauges and instruments and comparing the obtained data with the allowable limit range. This method has high accuracy, but the accuracy of measuring tools and instruments must be carefully checked before measurement and inspection, and measuring components must be reasonably selected.

[3] Exploratory inspection

For the inspection of covert defects of parts, exploratory inspection can be used. In the maintenance, the simplest oil immersion hammering method is generally adopted, i.e. to soak the inspected parts in kerosene or diesel oil for several minutes, then dry the surface after taking out, evenly spread talcum powder on the surface of the parts, and then lightly knock the non-working surface of the parts with a small hammer. As the hammering will cause the vibration of the parts, if the parts have cracks, the oil stains immersed in the cracks will splash out due to the knocking vibration, causing the talc powder on the surface to become yellow, thus showing a yellow line mark at the crack.

(IV) Repair methods and skills

In the repair process, after decomposition, cleaning, testing and other procedures, it enters the main body repair stage. Mastering basic repair skills is the key to ensure repair quality. The repair methods mainly include the following:

[1] Chisel, file, scrape

Chisel cutting is a method of processing metal parts by striking a chisel with a hammer. Its function is to chisel, cut and divide.

Filing is a processing method that uses a file to filing a layer of metal off the surface of a machine part. Filing can be divided into rough file and fine file. The surface roughness of the parts after filing is mainly determined by the thickness of the teeth of the file. The section shape of the file and the movement form of the file during filing are determined by the surface shape required by the machine parts.

Scraping is a process of scraping a thin layer of metal off the surface of a machine part with a scraper. As scraping is a kind of precision work, the allowance of scraping should not be too large, and generally, the amount of scraping at one time is about 0.005 ~ 0.01 m. During scraping, the surface of the machine part shall be coated with a layer of red lead powder, and the machine part shall be matched with flat plates, standard parts or finished fittings for grinding. The contact high point formed after matching and grinding shall be taken as the scraping object. After repeated matching, grinding and scraping, the high point and the secondary high point are gradually scraped off, so that the contact points on the surface of the scraped parts are increased to form the required shape and achieve precise matching of work.

[2] Grinding

Grinding is to use a grinding tool to grind a very thin metal layer off the surface of the machine part, so that the surface of the machine part has precise dimensions, accurate geometric shapes and very fine surface roughness. This is the most precise method for machining the surface of the machine part. It can be divided into

three types: flat grinding, inner hole grinding and outer circle grinding. The flat grinding tool is a flat plate and the inner hole grinding tool is a grinding rod. In the maintenance work, the crankcase plane and the inner holes of connecting rod big and small heads are often ground by grinding.

[3] Riveting and welding

Riveting is a method of connecting two or more parts together with rivets. Riveting methods are widely used in maintenance processes, such as riveting of clutch plates and riveting of various assemblies. Riveting can be divided into fixed riveting, movable riveting and close seam riveting according to its application.

Welding is a processing method that uses a welding tool and solder to firmly connect two metal surfaces together. It is widely used in maintenance technology. For example, the cracking recovery of welding spots on the frame and the cracking recovery processing of other parts.

[4] Drilling and reaming

Drilling is a method of machining holes in machine parts or materials with a drill bit. The main equipment and tools for drilling are radial drilling machines, bench drills, hand drills, hand drills, drill bits and jigs, etc.

Reaming is to improve the precision of the existing holes on the machine parts and reduce the surface roughness of the holes. Reamer is used to finish the holes. Reaming can improve the matching precision between the hole and the shaft. The precision of reaming can reach 6 ~ 8 grades. Reamer is the main tool for reaming. Reaming tools commonly used in repair work include fixed hand reamers, adjustable movable reamers and conical hand reamers. The bottom hole must be drilled before reaming. Drilling bottom holes is to set aside appropriate machining allowance for reaming process according to the precision requirements of forming holes of machine parts.

[5] Tapping thread and sleeving thread

Tapping internal threads is called tapping thread, and reaming external threads with a die is called thread die cut. The main tool for tapping threads is screw tap. Hand cones are usually composed of two sets (head cone and two cones). The bevel angles of the cutting parts of the two taps are different, the bevel angle of the head cone is small, and the bevel angle of the two cones is large. The bottom hole with chamfer must be drilled before tapping. The diameter of the drill bit for drilling the bottom hole can be found in a special table or calculated by the following formula:

Bore diameter = thread outer diameter - 1.1mm pitch (applicable to pig iron, bronze, etc.).

Bore diameter = thread outer diameter - 1.2mm pitch (applicable to steel, brass, etc.)

When tapping the thread, the head cone is first tapped along the chamfered bottom hole. After tapping, the thread is then formed by tapping with two cones.

The main tool for threading is die. The die is divided into fixed, adjustable and movable types. Commonly used is a fixed die, that is, a round. When sleeving threads, the die and bar stock with corresponding diameter shall be selected according to the required material, thread diameter and pitch. The dimension relation can be found in the special table or calculated by the following formula:

Rod diameter = thread outer diameter - 0.13mm pitch

Before threading, the end of the bar should be chamfered (15 ~ 20), and the minimum diameter at the taper angle should be smaller than the inner diameter of the thread, so that the die and the bar can be perpendicular and easily aligned for cutting.

[6] Correction

The operation to eliminate the flatness defect of plate, strip or cylindrical parts is called rectification. Correction is the plastic deformation of parts.

Therefore, only metal parts with good plasticity (such as low carbon steel, red copper, etc.) can be directly corrected. Metal parts with high carbon content can be rectified after annealing.

Methods of correction include torsion, stretching, bending and extension.

[7] Bonding

Bonding technology is widely used in manufacturing and repairing due to its advantages of simple process, no need for special equipment and precious materials, and no need for high-precision mechanical processing of bonded parts. For example, the bonding of handlebars and directional handlebars, the bonding of plastic signs and painted metal parts, the bonding of brake pads and brake shoes, etc. There are many kinds of adhesives, the

common ones are epoxy resin and phenolic resin.

(V) Motorcycle assembly

The final process of repair is assembly, which is the key to ensure that the vehicle reaches various technical indexes.

[1] Assembly is divided into assembly, component assembly and general assembly. In the process of assembly, the procedure of assembly of components first, assembly of components later, and final assembly shall be followed. The operation sequence of assembly is exactly opposite to that of disassembly, i.e. the assembly shall be carried out before the disassembly, and the assembly shall be carried out after the disassembly.

[2] Assembly of components is an early step in the whole assembly process. It connects several related parts into a single component. For example, the assembly of brake drum cover assembly, brake shoe assembly, wheel rim assembly and other components of the front wheel.

[3] The assembly of components is carried out on the basis of assembly. It is to assemble all the parts and components to which the component (assembly) belongs into an independent integral structure. For example, the assembly of front and rear wheel assemblies, front fork assemblies, shock absorber assemblies, etc.

[4] General assembly refers to the installation of all parts, assemblies and components of the whole vehicle onto the frame body in sequence through various connection methods to form a complete set of technological process.

[5] The main sequence of general assembly is basically the same. The operation steps are as follows: firstly, the assembly of all combined components and the assembly of all parts of the assembly are completed, and the engine assembly and the gearbox assembly are installed on the frame; Then install front fork assembly, handlebar assembly, front and rear fender assembly, shock absorber assembly, shelf assembly, front and rear wheel assembly, oil tank assembly, saddle assembly, etc. in sequence. On this basis, install headlamp, taillight, turn signal lamp, electric horn and battery assembly. Connect all electrical lines and all control ropes; Install transmission chains or toothed belts, various wind shields, chain covers or belt covers, etc.; Finally, lubricate the whole vehicle after assembly.

[6] Due to the different types and structures, the assembly sequence is also different. Please refer to the following disassembly, installation and inspection.

[7] Special attention should be paid to the following points during assembly:

Choose a clean and wide site; Strictly follow the installation sequence required by the assembly process; The connection between parts should meet the specified requirements, especially to prevent various gaskets, cotter pins and locking pieces from being installed incorrectly or missing.

III. Commissioning after maintenance

After repair, the interrelation between various parts is affected to a certain extent. In order to restore its proper performance index, the vehicle must be carefully adjusted according to the provisions of the service manual so that the connection between various parts meets the working requirements. The main adjustment items are as follows:

(1) Adjustment of ignition time

Incorrect ignition advance angle of the engine will cause difficulties in starting, decrease in power, increase in oil consumption, overheating of the engine, incomplete combustion, over-emission and reduction in service life. Therefore, the ignition advance angle must be adjusted first.

If the ignition system goes wrong, components such as electronic igniter, high voltage coil, ignition coil and trigger coil on magnetoelectric machine shall be checked.

(2) Clutch adjustment

Clutch is the key component to transmit power in transmission system, which must be adjusted according to the following overhaul contents. The content of the adjustment is mainly the free stroke of the clutch handle (generally 10 mm ~ 20 mm), and some vehicles need to adjust the adjustment screw of the separation mechanism.

(3) Adjustment of brakes

The brake performance is related to the driving safety. It is very important to adjust the brake correctly.

The brake adjustment items are the free stroke of the front brake grip (generally 10 mm ~ 20 mm) and the free stroke of the rear brake pedal (generally 20 mm ~ 30 mm). The adjustment method is basically the same and can be carried out according to the provisions of the following overhaul contents.

(4) Adjustment of electrical devices

The adjustment items of electrical devices mainly include the headlight and electric horn.

[1] For the headlights, adjust the lighting distance scope by swinging up and down the installation position of the headlamps.

[2] For the electric horn, adjusts the volume and tone. Generally speaking, the volume of motorcycle electric horn is set at (95 ~ 105) d b; If the volume is too high or too low, and the tone is too thick or too thin, it can be adjusted by the adjusting screw on the back.

(5) Adjustment of throttle line

The throttle knob shall maintain a free stroke of 2mm~ 6mm. During this process, the engine shall not suffer from speed increase and stall. Since the trip is too large or too small, it should be adjusted. This adjustment is generally coordinated with idle speed adjustment.

Section 3 Maintenance Adjustment Data

Table 2-1 Operation/braking/shock absorber/wheel maintenance adjustment table

Item	Standard value (mm)	Limit value (mm)
Free travel of front brake handle	1020	2030
Free travel of rear brake pedal	2030	3040
Free travel of refueling handle	26	1012
Tire tread depth	4.0	2.0
Front shock absorber travel	120	_____
Free length of front shock absorber spring	375	_____
Rear shock absorber stroke	40	_____
Free length of rear shock absorber spring	210	_____
Wheel hub runout	Axial direction	_____ 0.8
	Radial direction	_____ 0.8
Axle runout	Front	_____ 0.8
	After	_____ 0.8

Table 2-2 Maintenance cycle table

Maintenance items		Number of repairs	Item	Mileage indicator km			
				Cycle	1000km	4000km	8000km
	Fuel system			I	I	I	I
	Fuel filter		A	R/I	R/I	R/I	R/I
	Control system			I	I	I	I
	Damper cable			I	I	I	I
	Air filter element		A/R	R	R	R	R
	Spark plug gap			I	I	I	I
	Valve clearance			I	I	I	I
	Drive chain			I/L	I/L	I/L	I/L
	Battery			I	I	I	I
	Brake shoe abrasion			I	I	I	I
	Braking System			I	I	I	I
	Brake lamp switch			I	I	I	I
	Headlight Dimming			I	I	I	I
	Main side bracket			I	I	I	I
	Front shock absorber			I	I	I	I
	Nuts/bolts/fasteners			I	I	I	I
	Front and rear wheel casings			I	I	I	I
	Steering mechanism bearing			I	I	I	I

Motorcycles should be repaired according to the above specified time. The meanings of various symbols in the above table are as follows:

R- cleaning, A- inspection, L- lubrication, I- inspection, cleaning, adjustment, lubrication or replacement

This item will be repaired by our after-sales service personnel. Please refer to this manual if you repair it yourself.

This item is suggested to be carried out by the after-sales service personnel of our company to ensure driving safety.

 Caution

- When driving in dusty areas, the maintenance cycle should be shortened appropriately.

Table 2-3 Tightening torque table

	Item	Specifications	Torque value(N.m)
Motorcycle	Vertical pipe lock nut	M241	67~75
	Handlebar fixing bolt	M620	8~12
	Front axle nut	M141.5	85~95
	Rear axle nut	M141.5	85~95
	Engine suspension bolt	M816	28~32
	Rear shock absorber retaining nut	M121.25	85~95
	Sprocket fastening nut	M8	28~32
	Rear rocker shaft nut	M101.25	65~75
	Flat fork shaft nut	M141.5	85~95
	Flat fork shaft nut	M141.5	85~95

Chapter III Vehicle Parts

Section 1 Oil Supply System

The oil supply system consists of fuel tank, fuel pump, fuel injector, fuel filter, oil pipe, etc.

I. Structure and working principle of the fuel system

[1]Fuel tank

The fuel tank is usually formed by punching and welding a steel plate with a thickness of 0.8mm ~ 1.0mm. Some fuel tanks are also welded with perforated baffles inside, which not only improves the strength of the fuel tank, but also prevents the fuel from surging in the running of the vehicle. Due to the strong corrosiveness of gasoline, the inner surface of the oil tank shall be subjected to anti-corrosion treatment such as galvanizing. The top of the fuel tank is provided with a filling port and is covered with a fuel tank cover with a vent hole, so that the fuel can be prevented from overflowing while the motorcycle is running, and the air pressure inside and outside the fuel tank can be balanced, so that the fuel can naturally flow out.

[2]Fuel pump

The fuel pump assembly consists of an oil pump, a bracket and an oil pressure regulator. The elastic installation method can reduce the direct influence of vibration on the fuel pump. Installed in the oil tank, the oil supply system has a simple structure and is not prone to fuel leakage.

The fuel pump is a turbine-type single-stage electric fuel pump, driven by a 12-volt DC motor and controlled by ECU through a fuel pump relay. A one-way valve is designed at the outlet of the oil pump. When the engine is not working, the oil stored in the oil pipe will not drain back to the oil tank to ensure restart performance.

[3]Fuel injector

The fuel injector injects a proper amount of atomized fuel into the intake pipe of the engine timely and accurately through the ECU, and then is sucked into the cylinder to participate in combustion.

[4]Fuel filter



The fuel filter is connected in series on the oil path between the electric fuel pump and the fuel rail. In order to ensure the filtering effect and prevent the nozzle from clogging due to foreign matters, the system needs to adopt a special fuel filter for EFI. The shell of the filter must be strong enough not to be cracked due to fuel pressure.

[5]Fuel pipe

The fuel supply pressure of the system is 250k Pa. For safety consideration, the selection of fuel pipe must have sufficient safety factor.

II. Disassembly and maintenance of the fuel system

[1] The capacity of the motorcycle fuel tank is 20L.

When filling fuel, it must be carried out in a well-ventilated field with good air circulation and away from sparks and flames.

⚠ Warning

- Fuel oil is flammable. Smoking and approaching open flames are strictly prohibited.
- The motorcycle should be shut down and operated in a ventilated place.

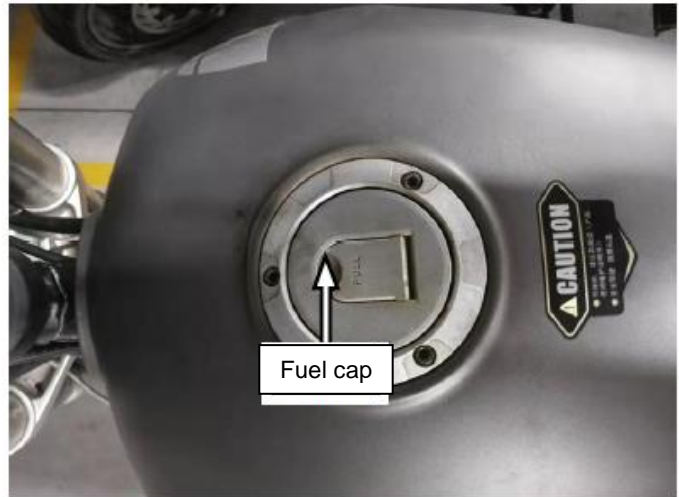

[2] If the fuel tank cover leaks, the sealing rubber ring of the fuel tank cover must be replaced.

⚠ Warning

- Fuel oil shall be gasoline with brand 92# and other fuels are prohibited.



[3] Check the fuel tank for oil leakage. If oil leakage occurs in the fuel tank, the fuel tank must be repaired or replaced.

⚠ Caution

- If the fuel tank is impacted by an external force to cause deformation such as pits, the pits can be knocked up with a wooden hammer. If the fuel tank is cracked, it is better not to repair it, and the fuel tank must be replaced.



[4] Check the fuel pipe for oil leakage or aging, and check whether the fuel filter is blocked. If the fuel filter is blocked, the fuel filter must be cleaned or replaced.

⚠ Caution

- The fuel pipe must be replaced if it leaks oil and is aged.
- When replacing the fuel pipe or fuel filter, the ignition switch must be turned off to stop the operation of the fuel pump and prevent the fuel in the fuel tank from flowing out.

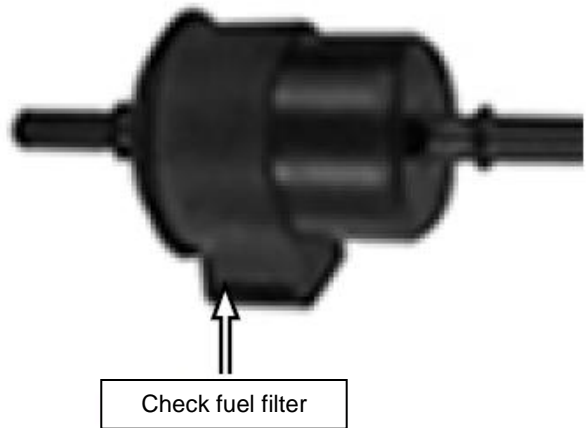

[5] First remove the left and right side covers and seat cushion. Then remove the fuel tank fixing bolt and take out the fuel tank.

⚠ Warning

- When releasing fuel, the fuel must be kept away from the fire source to avoid fire.

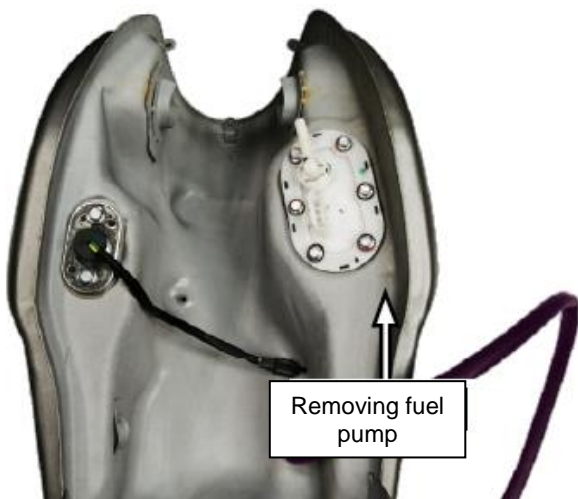

[6] Remove 6 M412 fixing bolts of fuel pump with Allen wrench tool.

⚠ Warning

- When disassembling the fuel pump, the fuel must be discharged first and kept away from the fire source to avoid fire.

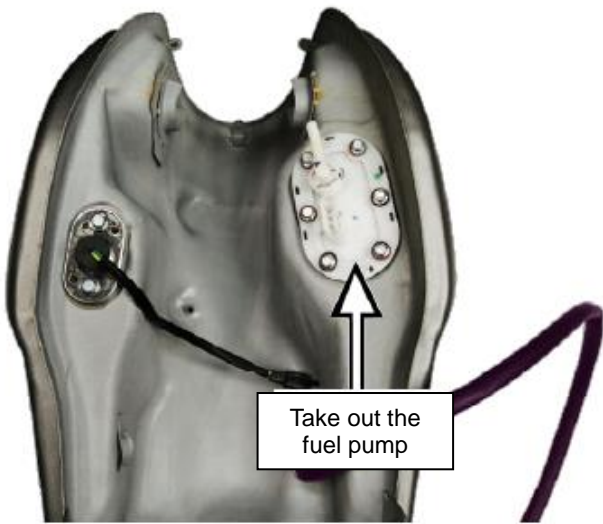

[7] Remove the fuel pump. Clean the oil residue and water in the fuel tank with cleaning agent.

⚠ Caution

- After the fuel tank is cleaned, it must be placed in a well-ventilated place to dry before it can be used.



[8] Check whether the sealing rubber ring of the fuel pump is aged or cracked, whether there is oil immersion, and if so, replace the sealing rubber ring of the fuel pump.

[9] Check whether the fuel pump motor rotates and clean or replace the fuel filter screen.

⚠ Suggestion

- The fuel filter should be replaced when the motorcycle is running at 8000~10000Km.

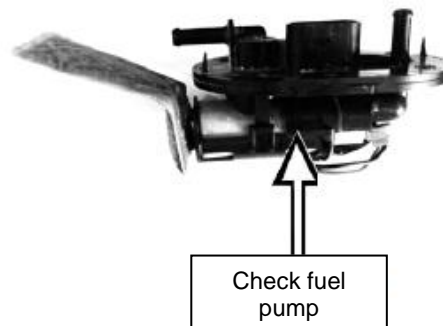

III. Oil supply system damage form, fault phenomenon and common maintenance methods are shown in table 3-1:

Table 3-1 Maintenance of oil supply system

Part name	Damage form	Component failure phenomenon	Vehicle failure phenomenon	Maintenance method
Fuel tank	Rust through the box	Oil leakage from fuel tank		Repair or replace the fuel tank
	The vent hole of the tank cap is blocked	Poor oil supply	The motorcycle cannot start	Dredge the vent of the tank cap
	Fuel tank deformation	The fuel tank is uneven	Motorcycles have poor appearance	Repair or replace the fuel tank
Fuel pump	The oil filter is too dirty or the small hole is blocked	Poor oil supply	Motorcycle is difficult to start or cannot start, engine power is insufficient, and engine idle speed is unstable.	Clean the fuel filter screen
	Blockage of fuel pump body	Poor oil supply	The motorcycle cannot start	Clean or replace the fuel pump
	The fuel pump motor does not rotate	No oil supply	The motorcycle cannot start	Replace the fuel pump motor
	Blockage of oil pressure regulator	No oil return	Oil guide pipe bursts	Clean or replace the fuel pump
	The oil pressure regulator is always open	Oil supply pressure is low.	Motorcycle is difficult to start or cannot start, engine power is insufficient, and engine idle speed is unstable.	

Section 2 Cooling System

The engine is an internal combustion engine operating at high temperature. Many parts of the engine are subject to considerable heat load, especially the cylinder head, cylinder block, piston, valve and other parts are in high temperature gas state. Improper cooling measures will cause the engine to overheat. Parts that bear high temperature are easy to burn out, and parts that cooperate with each other will also have excessive clearance due to large thermal expansion. Excessive temperature will also cause deterioration of lubricating oil, or even engine damage. Therefore, an efficient cooling system is very important to the engine.

The main function of the engine cooling system is to take away the heat from the surface of high-temperature components and control the engine temperature within the allowable range. The motorcycle cooling system is water-cooled.

I. Structure and working principle of cooling system



Water cooling takes water as the medium to take away the heat of high temperature parts, reduce their temperature and dissipate the heat to the atmosphere. Water cooling system includes: water tank, water pump, water jacket, fan, thermostat, radiator, etc.

Water tank: used to store cooling water.

Water pump: Water pump is the power source of water circulation. It is driven by engine. Water-cooled motorcycles generally use centrifugal pumps.

Water jacket: Water jacket is a place where water exchanges heat with high-temperature parts, and is generally arranged around the cylinder block and cylinder head.

Radiator: The radiator is exposed in the air and located on the windward side of the motorcycle, where the high-temperature water dissipates the heat from the engine into the air and becomes low-temperature water.

Working principle of the water cycle

The low-temperature water in the radiator is pumped into the water jacket by a water pump. After exchanging heat with the high-temperature cylinder block and cylinder head, it becomes high-temperature water and flows into the thermostat. At this time, according to the water temperature, there are two ways of water circulation:

[1] When the water temperature is lower than the specified value, the valve of the thermostat is closed, and the water flowing from the water jacket flows into the radiator from the low-temperature water outlet to participate in the circulation. the cross-sectional area of the low-temperature water outlet is very small, so the flow rate of circulating water is very small at this time.

[2] When the water temperature is higher than the specified value, the thermal expansion body senses the water temperature, expands and resists the piston. Since the piston is fixed, the piston sleeve drives the valve to move downward. In this way, when the valve is opened, water flows from the high-temperature water outlet and the low-temperature water outlet to the radiator at the same time, thus increasing the flow rate and enhancing the cooling effect.

After the high-temperature water flows into the radiator, the water temperature decreases and flows back to the water pump for recirculation. A temperature control switch is arranged at the outlet of the radiator, which mainly monitors the water temperature of the water cooling system and displays it on the instrument panel to prompt the driver.

Working principle of water quantity control

In order to ensure the normal operation of the water cooling system, it is necessary to ensure that the water quantity in the circulating water channel is constant. The cooling water quantity is generally indicated on the water tank or on the motorcycle, and the cooling water quantity of this motorcycle is 800 mL. The upper part of the water tank is provided with vent holes, and the water quantity in the circulating water channel is controlled between the water tank and the radiator cover through siphon pipes. The radiator cover has the function of automatically adjusting the water quantity in the circulating waterway, and its working principle is as follows:

[1] When the water temperature in the circulating waterway is too high and the water pressure exceeds a certain pressure value, the pressure valve will automatically open, and some water in the waterway will flee back

into the water tank.

[2] When the water temperature in the circulating water channel drops, a large negative pressure will be generated. If the negative pressure drops to the specified value, the vent valve will open. Due to siphon effect, the water in the water tank will flow into the circulating water channel.

Coolant mixture concentration meter

Minimum temperature resistance	Mixed concentration	Coolant	Distilled water
above -15	30	1.2L	2.8L
Below -16	30	2.0L	2.0L

II. Disassembly and maintenance of the cooling system

[1] Selection of coolant

[1] Engine cooling system will lead to overheating of the engine, so maintenance of the cooling system is very important.

The cooling medium used in the water cooling system is actually the cooling liquid formed by mixing distilled water with the original cooling liquid. It not only has the function of cooling, but also has the functions of antirust and antifreezing. At the same time, mixing is carried out according to different temperatures in different regions, and the proportion of cooling liquid with different temperatures in different regions is different. Users prepare the cooling liquid according to the mixed concentration and the standard of 5 lower than the actual temperature. Distilled water should be used in preparation, and tap water and other impure water should not be used to avoid scale formation.

[2] Replacement of coolant

First, after the engine is cold for 20 minutes, open the water tank cover.

Unscrew the coolant release screw and drain the coolant.

After draining the coolant, retighten the release screw.

Slowly inject coolant from the hole of the attached water tank cover to keep the liquid level at the edge of the hole.

Start the engine and keep it running at idle speed. After the bubbles in the circulating water channel are completely exhausted from the attached water tank cover, turn off the engine.

Refill the coolant to the edge of the cover hole of the attached water tank.

Coolant is a poisonous liquid and must not be drunk. If it sticks to the skin, wash it with clear water in time. If it sticks to the car body, wipe it off in time.

There is a water leakage hole under the water pump. If coolant flows out of the hole, the water seal is not tight and a new water seal or water pump needs to be replaced.

[3] Inspection of Radiator

The maintenance of the radiator is mainly to remove the dirt between the radiating fins in time.

III. Cooling system damage form, fault phenomenon and common maintenance methods are shown in table 3-2:

Table 3-2 Maintenance of Cooling System

Part name	Damage form	Component failure phenomenon	Vehicle failure phenomenon	Maintenance method
Water tank	The water tank is cracked	The engine lacks cooling water	Water tank leaks	Repair or replace the water tank
	There is no water in the water tank	The engine lacks cooling water	The engine has poor heat dissipation.	Supplementary cooling water
Radiator	Too much dust	Engine power drop	Engine overheating	Cleaning radiator fins
	Heat dissipation segment	The engine has poor heat dissipation.	Engine overheating	Replace radiator
Connecting water pipe	Damage aging	The connecting pipe leaks water	Engine overheating	Replace the connecting water pipe
Water pump	Turbine damage	Engine cooling water circulation power is insufficient	Engine overheating	Replace the water pump turbine
	Damaged or aged water seal	Water pump leaks	Insufficient cooling water power, engine overheating	Replace water seal
Thermostat	Thermostat broken	Water leakage	Engine overheating	Replace thermostat
	Thermostat blocked	The thermostat does not conduct water	There is no cooling water in the engine water jacket. The engine is overheated	Replace or repair thermostat

Section 3 EFI System

The main function of the EFI system is to atomize the fuel supplied from the fuel tank, mix it with air to form a uniform mixture and introduce it into the combustion chamber.

I. Structure and working principle of EFI system

The EFI system is mainly composed of electronic control unit (ECU), nozzle, throttle valve body assembly, intake air temperature and pressure integrated sensor, engine temperature sensor, ignition coil, crankshaft position sensor, oil pump assembly and oxygen sensor.

The EFI management system of the engine can accurately control the mixing ratio of air and fuel entering the cylinder of the engine, the combustion process and the exhaust gas conversion, so as to optimize the performance of the engine, improve the driving performance, and more strictly control the pollution of the exhaust gas emitted by the motorcycle to the air.

The engine control unit (ECU) is a microprocessor with a single chip microcomputer as its core. The engine control module analyzes the working state of the engine through sensors and work request switches installed at different positions of the engine and the vehicle body, judges the working state of the engine, passes through actuators on the engine and the vehicle body, and accurately controls the engine and corresponding mechanisms.

The engine speed and crank angle sensors are magnetoelectric, and the system uses them to determine the position and speed of crankshaft rotation.

The crank angle sensor is mounted on the transmission clutch housing and works together with the 24x ring gear on the flywheel.

An intake pipe absolute pressure (MAP) sensor is installed in the intake pipe to measure the pressure of the intake pipe, and ECU judges the amount of air entering the engine through this signal.

MAP sensor consists of a sealed elastic diaphragm and a ferromagnetic core, the diaphragm and the magnetic core are accurately placed in the coil. when pressure is sensed, a 0~5V output signal proportional to the input pressure is generated.

The throttle position sensor is mounted on the throttle body assembly and coaxial with the throttle lever and throttle valve. It is a linear variable resistance structure, and its sliding terminal is driven by the throttle shaft.

With different throttle opening, the resistance signal reflected by the sensor to ECU is also different. The system judges the real-time load and dynamic change status of the engine according to the signal value output by the sensor and its change rate, so as to control the engine accurately in time.

The air temperature sensor is installed on the transition pipeline of the intake system to detect the air temperature entering the engine. It also uses a thermistor with negative temperature coefficient as the sensing element.

Since the change of gas temperature will directly affect its density change, air temperature sensor is one of the important parameters for calculating the actual air quantity entering the cylinder.

The nozzle structure is an electromagnetic switching device. The coil lead-out poles are communicated with the ECU through an engine wire harness. After the coil is controlled by the ECU and subjected to electric pressure, magnetic force is generated to overcome the spring force, the pressure of fuel oil and the vacuum suction force of the air inlet pipe to suck up the iron core, and the fuel oil passes through the sealing surface of the ball valve integrated with the iron core and is sprayed out of the guide spray hole to form atomized fuel injection. After the power is cut off, the magnetic force disappears and the nozzle is closed.

The top of the fuel injector adopts a rubber sealing ring and a fuel rail interface to form a reliable pressure fuel seal; The lower part also adopts rubber sealing ring to form air seal with the intake pipe of the generator. The nozzle atomizes the fuel to the intake valve.

The throttle valve body is installed in front of the intake pipe. The throttle valve body consists of a valve body, a throttle position sensor, an idle speed control valve, etc. The main function is to control the intake air volume when the engine is working. It is the most basic dialogue channel between the electronic control system and the driver.

The oxygen sensor is installed on the exhaust pipe of the engine and is an important landmark part of the closed-loop fuel control system.

The main sensitive material of oxygen sensor is zirconia. After zirconia is activated by exhaust gas heating (300), oxygen ions pass through zirconia element and reach its external electrode. Zirconia element senses the oxygen content in engine exhaust gas and changes its output voltage.

The oxygen sensor is made of Teflon insulated wires and stainless steel molded components. The reference air is input by wires and there is no blocking problem.

When the air-to-air ratio participating in engine combustion becomes lean, the oxygen aggregation content in exhaust gas increases and the output voltage of oxygen sensor decreases; On the contrary, the output voltage value increases, thus feeding back the real-time air-to-space ratio state of the engine to the ECU.

II. Disassembly and maintenance of EFI system

The motorcycle EFI system has passed the commissioning before leaving the factory. When the EFI system fails, it is strictly prohibited to adjust the idle screw on the throttle valve body and to replace or adjust the components of the EFI system. If you have any questions, please visit our special service station for maintenance.

The motorcycle EFI system is equipped with an EFI malfunction indicator lamp on the meter. When the ignition system circuit is turned on, the indicator lamp will be on for a long time under normal working conditions. If there is a failure, the lamp will not be on. When the engine is started, the lamp goes out under normal working conditions. In case of failure, the lamp will turn on or flash continuously.

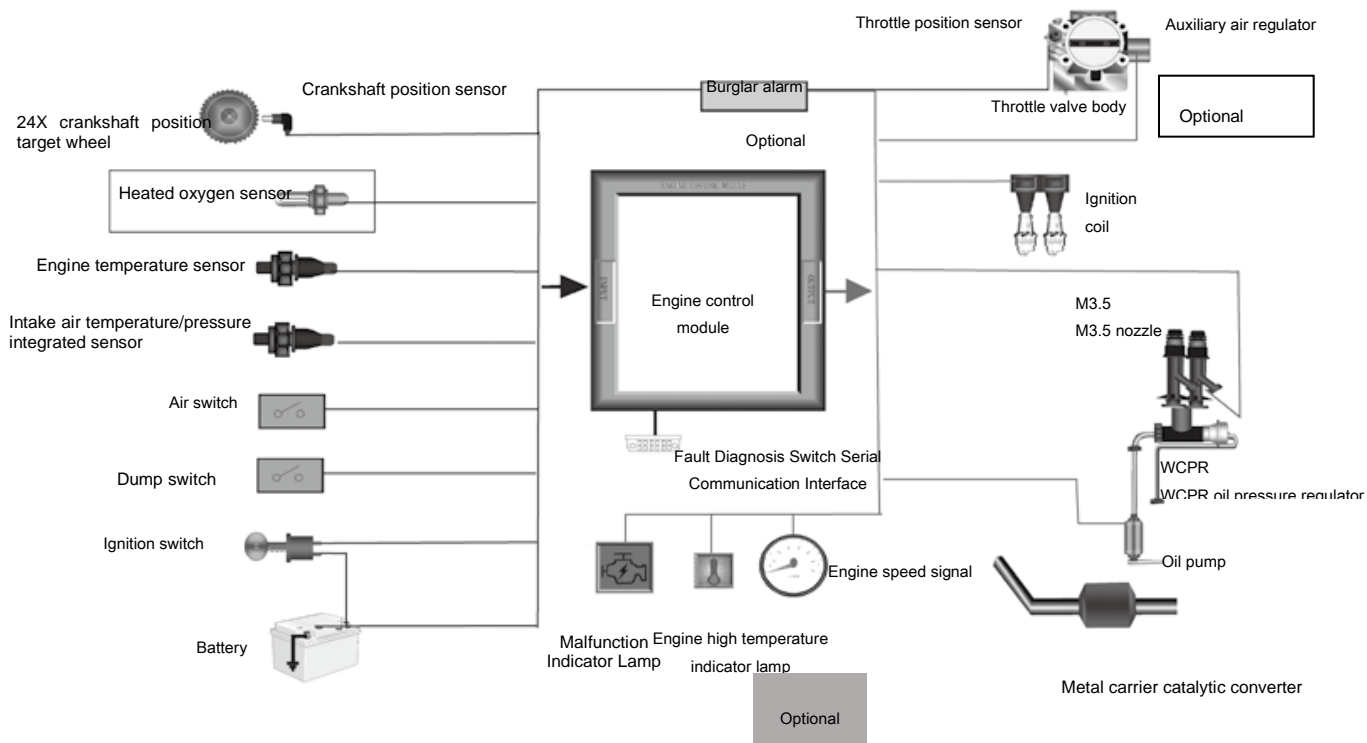

Structural schematic diagram of EFI system

III. Common fault of EFI system

Diagnose the EFI system with a scan tool to see if there is any fault information. If there is a fault, replace the corresponding EFI parts. If there is no fault, please check as follows:

1. Check whether the line connection is normal and damaged;
2. Check whether the voltage is above 9V;
3. Check whether the vehicle insurance and EFI insurance are damaged;
4. Check whether the oil circuit is normal and whether the oil pipe is blocked, squeezed or damaged to ensure smooth oil circuit.

Section 4 Air Intake and Exhaust System

The air intake system of motorcycle engine consists of air filter and air intake pipe. The main function of the air intake system is to guide and filter the empty air, reduce the air intake noise and control the amount of mixed air entering the engine.

The exhaust system mainly consists of exhaust pipe and muffler. The main function of the exhaust system is to remove the exhaust gas after the engine works into the large gas, reduce the noise and temperature of the exhaust gas, and eliminate the flame spark in the exhaust gas. A good exhaust system can also improve the intake and exhaust efficiency, increase the power of the engine, reduce oil consumption, etc. The exhaust system includes an exhaust pipe and a muffler, called an exhaust muffler.

I. Structure of the air intake system

[1] Structure and working principle of air filter

Air filter is an important component in the air intake system. Its function is to filter and purify the air entering the cylinder and prevent dust and sand particles from entering the cylinder, so as to reduce the wear of the cylinder, piston and piston ring. Its working performance has great influence on the engine's power, air intake noise and service life. The test shows that if the air filter is not installed, the wear amount of the cylinder will increase by 8 times, the wear amount of the piston will increase by 3 times, and the wear amount of the piston ring will increase by 9 times, greatly reducing the reliability of the engine and shortening its service life. Therefore, the motorcycle must be equipped with air filters when in use. On the premise of satisfying the filtering effect, the air filter is required to have small air flow resistance so as to improve the intake air volume of the engine. The work should be reliable, the structure should be simple, the external dimensions should be small, the weight should be light, and the maintenance should be convenient. The air cleaner is mainly composed of a filter cartridge and a sealed shell. When the engine is running, air enters the front chamber of the air cleaner through the air duct, flows to the rear chamber of the air cleaner after being filtered by the filter element, and then enters the throttle valve.

[2] Structure and working principle of intake pipe



The intake pipe is an important part connecting the throttle valve and the engine intake port, and the intake pipe also supports the throttle valve. Its structure is simple, and its bending shape is mainly determined according to the corresponding position of throttle valve and engine inlet, but the influence of the filter on the intake resistance. The length of the gas channel is favorable for fuel atomization, but the gas resistance is large. Short air passage is unfavorable for fuel atomization, but has little resistance to gas.

The mixed gas atomized by the fuel injector enters the engine cylinder from the air inlet of the engine through the air inlet pipe, which reduces the heat transfer from the engine to the throttle valve and isolates the influence of engine vibration on the throttle valve.

II. Structure and working principle of exhaust system



The exhaust pipe in the exhaust muffler is bent from a steel pipe. It is located between the exhaust port of the engine and the muffler. Its function is to guide the exhaust gas from the engine to the muffler.

III. Disassembly and maintenance of air intake system

[1] Remove the air filter element cover screw and take out the air filter element assembly.

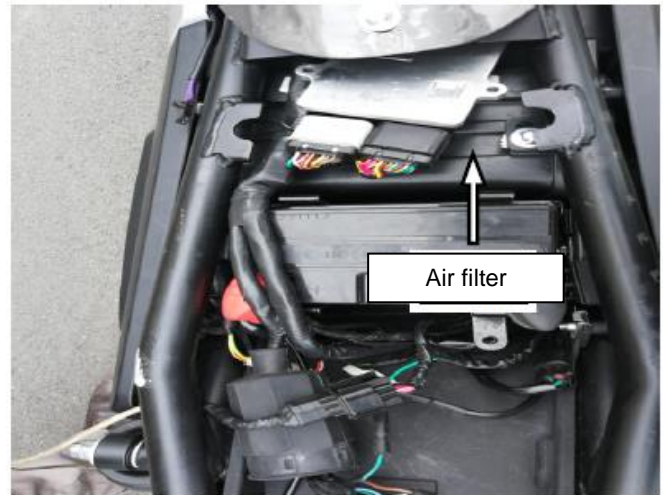

[2] Check whether there is too much dust in the filter element of the air cleaner. If there is too much dust in the filter element, replace the filter element.



IV. Disassembly and maintenance of exhaust system

[1] Remove the muffler exhaust pipe lock nut and muffler suspension bolt, check whether the muffler suspension bracket is broken, and re-weld when the muffler suspension bracket is broken.

⚠Caution

- When the muffler suspension bracket is broken, it needs to be replaced or re-welded.

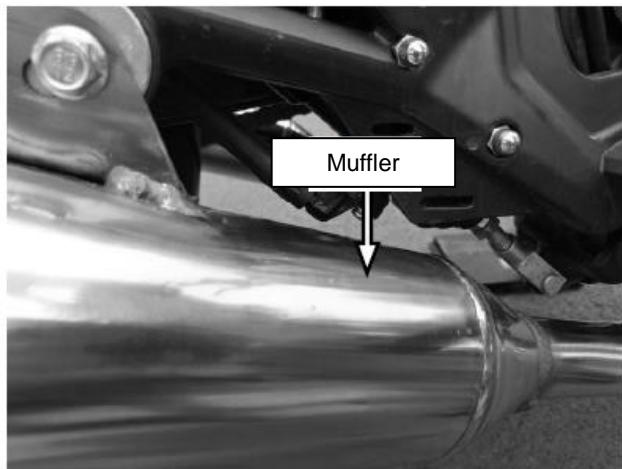
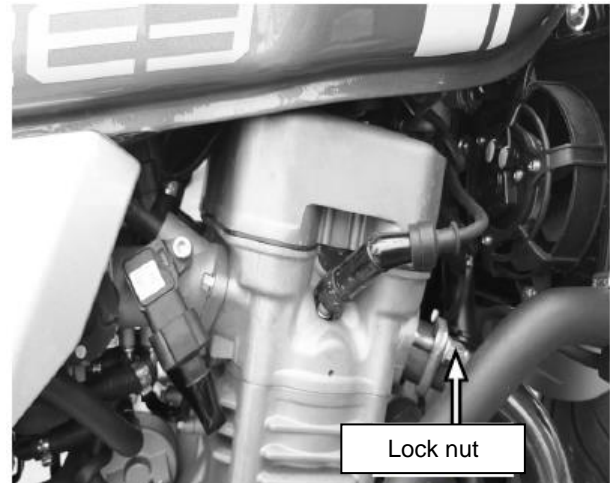

[2] Remove the muffler. Check whether the silencer is broken or damaged. When the silencer is broken or damaged, the silencer shall be welded or replaced.



[3] Remove the muffler sealing gasket and check whether the muffler sealing gasket is damaged. When the muffler sealing gasket is damaged, replace it with a new one.

⚠Caution

- Every time the muffler is disassembled and assembled; a new sealing ring must be replaced.



Muffler pipe section

[4] Check whether there is carbon deposit in the muffler pipe and remove the carbon deposit in the muffler pipe.

⚠Caution

- Check the muffler for rust or crack, and replace or repair it if necessary.

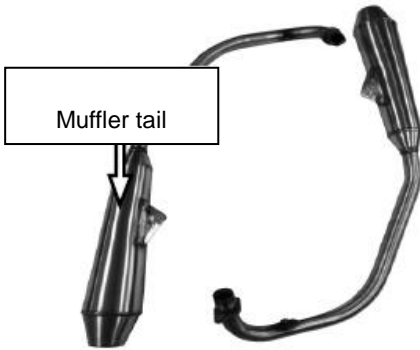

Muffler tail

[5] Check whether there is the carbon deposit in the tail of the muffler and remove the carbon deposit in the tail of the muffler.

V. Intake and Exhaust System Damage Forms, Fault Phenomenon and Common Maintenance Methods are Shown in Table 3-3:

Table 3-3 Maintenance of intake and exhaust system

Part name	Damage form	Component failure phenomenon	Vehicle failure phenomenon	Maintenance method
Air intake system	Too much dust in filter cartridge	—————	The engine is difficult to start, the engine has insufficient power, the engine idle speed is unstable, the fuel consumption is excessive, and the exhaust muffler emits black smoke.	Clean the filter cartridge or replace it
	The air cleaner housing is broken or cracked	—————	The engine intake noise is high.	Replace the air cleaner housing
Exhaust system	Air leakage at exhaust pipe outlet		Engine exhaust noise increases	Replace the exhaust pipe gasket
	Damaged exhaust muffler shell	—————	Engine exhaust noise increases	Replace the exhaust muffler.

Section 5 Fuel Evaporation System

I. Working principle of fuel evaporation system:

By installing a carbon canister device and closing the fuel tank at the same time, the fuel vapor in the fuel tank can only be connected to the atmosphere through the carbon canister. When the vehicle is stationary, the fuel vapor in the fuel tank will enter the carbon canister through the carbon canister adsorption port and be adsorbed on the activated carbon in the carbon canister. The release port of the carbon canister is installed on the air inlet pipe. When the two vehicles are running, the negative pressure in the connecting pipe will send the fuel vapor adsorbed on the carbon canister activated carbon back to the engine for combustion via the carbon canister solenoid valve. Thereby reducing pollution.

National emission and fuel evaporation working diagram

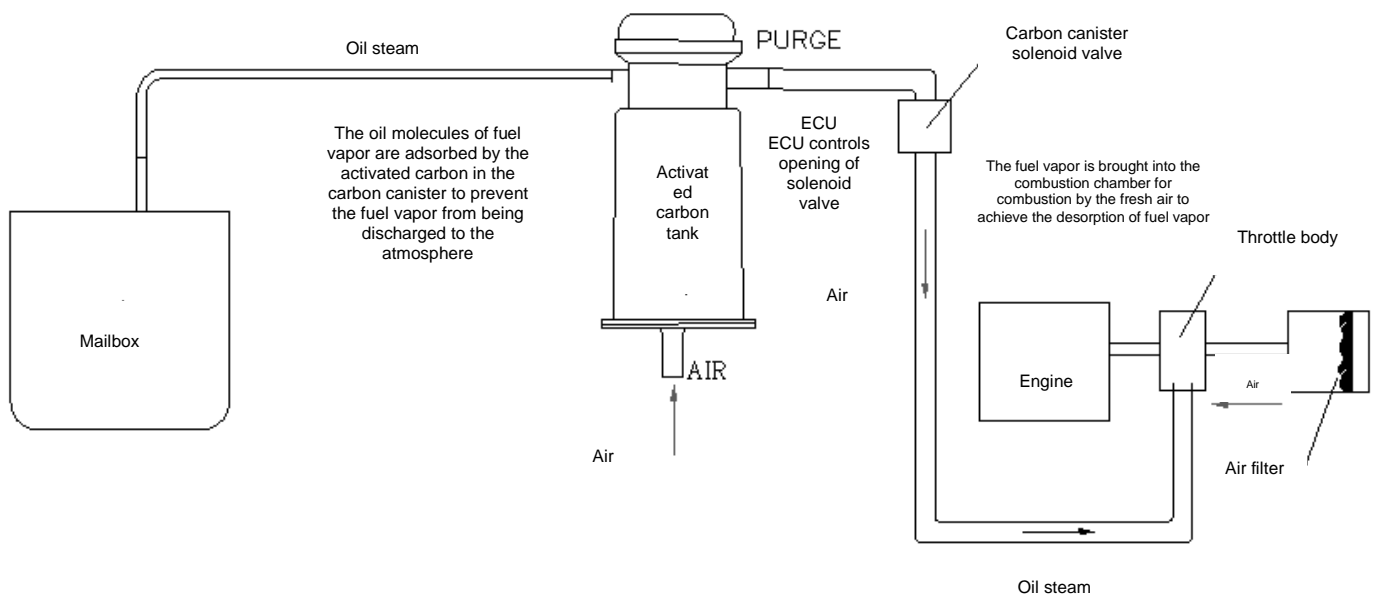

When a large amount of incompletely combusted mixed gas flows into the hot catalytic converter, it will generate the phenomenon of re-combustion, which will lead to overheating of the catalytic converter and make the catalytic converter invalid. In order to prevent this phenomenon and other damages, please pay attention to the following items:

[1] Limit the use of unleaded gasoline (92# unleaded gasoline), and use of leaded gasoline will lead to failure of catalytic converter.

[2] When the locomotive is running, do not turn off the main switch or slide in neutral to avoid the generation of a large amount of incomplete combustion mixed gas.

[3] If the ignition or combustion system of the locomotive is not working properly, it will also cause the catalyst converter to overheat.

[4] After the locomotive runs for a period of time, the surface of the exhaust pipe will become very hot, so extra care should be taken.

[5] During refueling, do not spill or overflow the gasoline on the exhaust pipe (burning may occur when the high-temperature exhaust pipe contacts the gasoline).



Warning

- Avoid dumping the vehicle, causing the fuel to leak out of the fuel tank and enter the canister, thus causing the canister to fail.
- Ensure that all pipelines of the fuel evaporation system are firmly connected to prevent fuel vapor from directly discharging into the atmosphere to cause pollution due to loosed pipes.
- Do not adjust the carburetor at will.

II. Maintenance of Fuel Evaporation System.

When repairing the fuel evaporation device, the motorcycle professional maintenance station personnel or the company's after-sales service personnel must carry out correct maintenance, so as to eliminate the fault in time, prolong the service life of the fuel evaporation device and reduce the maintenance cost. Ensure the best performance of the fuel evaporation device and achieve the goals of environmental protection and pollution reduction for motorcycles.

The specific maintenance method is carried out according to the following steps:

[1] Check whether the air intake negative pressure hose clamp, air intake rubber hose clamp and air intake iron pipe fixing bolt are loose. If the above situation occurs, tighten or replace the clamp.

[2] Check whether the air intake negative pressure hose and the air intake rubber hose are aging, leaking or damaged. If the above situation occurs, replace the air intake negative pressure hose and the air intake rubber hose.

[3] Check the operation of the canister and anti-dumping valve. If the canister and anti-dumping valve are blocked or cannot work normally, replace the canister and anti-dumping valve.

[4] Check whether the air filter is blocked or damaged. If the above situation occurs, replace the air filter.

[5] Check the working condition of the catalytic catalyst device. If the catalytic catalyst device is damaged and cannot work normally, the catalytic catalyst device must be replaced.

III. Fuel evaporation system damage form, fault phenomenon and common maintenance methods are shown in table 3-4:

Table 3-4 Maintenance of Fuel Evaporation System

Part name	Damage form	Component failure phenomenon	Vehicle failure phenomenon	Maintenance method
Fuel evaporation device	The evaporation pipe of the oil tank is blocked	Oil vapor in the oil tank cannot be discharged smoothly.	The air pressure in the oil tank is too high, and the oil vapor is directly discharged to the atmosphere	Dredge the evaporation pipe of the fuel tank or replace the fuel tank
	Anti-dumping valve clogging	Oil vapor cannot be smoothly discharged to the canister	The air pressure in the oil tank is too high, and the oil vapor is directly discharged to the atmosphere	Dredge or replace the anti-dumping valve
	Anti-dumping valve damaged	Oil vapor cannot be smoothly discharged to the canister	The air pressure in the oil tank is too high, and the oil vapor is directly discharged to the atmosphere	Replace the anti-dumping valve
	Loose connecting rubber hose	Air leakage at air inlet	Oil vapor is directly discharged to the atmosphere	Replace the connecting rubber hose
	Blockage of carbon canister	Oil vapor cannot be smoothly discharged to the canister	The air pressure in the oil tank is too high, and the oil vapor is directly discharged to the atmosphere	Dredge or replace carbon canister
	Damaged canister	Air leakage from carbon tank	Oil vapor is directly discharged to the atmosphere	Replace carbon canister
	Damage to catalytic catalyst device	—————	Motorcycle emissions do not meet the national iii standard.	Replace catalytic catalyst unit

Section 6 Rear Transmission

Because the torque output by the motorcycle engine is relatively small and the rotation speed is relatively fast, the torque of the engine must be increased after three stages of deceleration to ensure the normal running of the motorcycle. The first-stage deceleration is carried out through the master-slave gear of the clutch; The second-stage deceleration is to decelerate through the main and auxiliary shafts of the transmission. Three-stage deceleration is to decelerate through the master and slave gears of the rear transmission device so as to utilize the power and rotational speed output by the engine more economically and reasonably.

I. Structure and working principle of rear transmission

The motorcycle rear transmission device is a chain transmission mode and mainly consists of a driving gear, a driven gear, a transmission chain, a chain joint, a transmission chain box, a chain regulator, a buffer rubber block and the like.



Firstly, power is output through the driving sprocket at the end of the auxiliary shaft (power output shaft) of the engine transmission, then the power is transmitted to the driven sprocket through the transmission chain, after three-stage deceleration, the driven sprocket is fixed on the buffer body by bolts, and the buffer body is connected with the rear hub through the Therefore, when shifting gears during driving, the power is flexibly transmitted through the buffering of the rubber parts, thus avoiding the abrasion between parts and improving the comfort and stability of the motorcycle during driving.

II. Disassembly and maintenance of rear transmission device

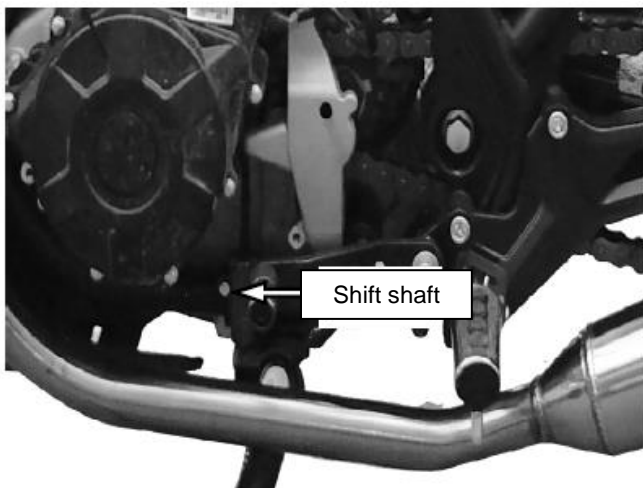

[1] Remove the retaining bolt of the shift pedal and remove the shift pedal.



[2] Remove the fixing bolts of the left rear case cover of the left crankcase body and the left rear case cover of the left curved shaft case body.

[3] Check the wear of the small transmission sprocket and replace the large and small sprockets in a complete set if necessary.

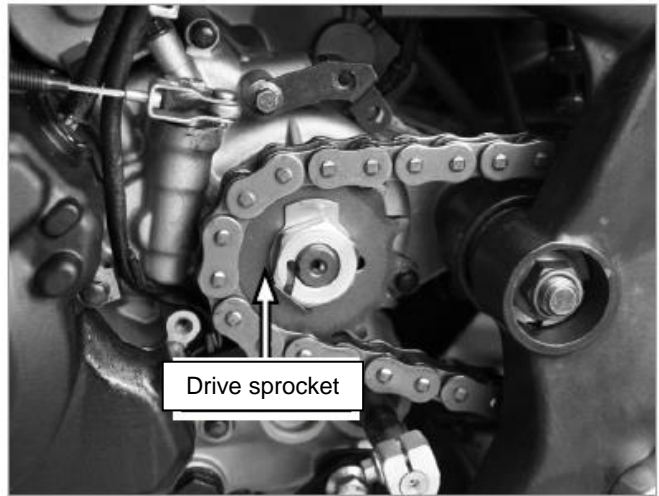

[4] Remove the chain box fixing bolt and the chain box.

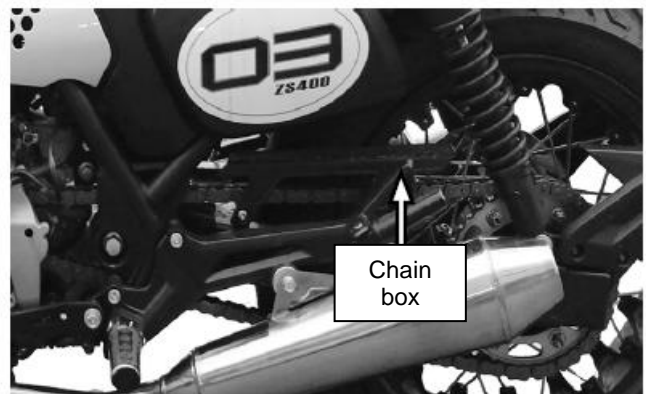

[6] Check the wear and deformation of the transmission chain, and replace the large and small transmission chain wheels and the transmission chain in a complete set according to the actual wear of the transmission chain.

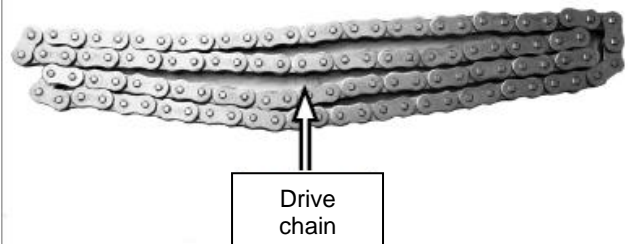

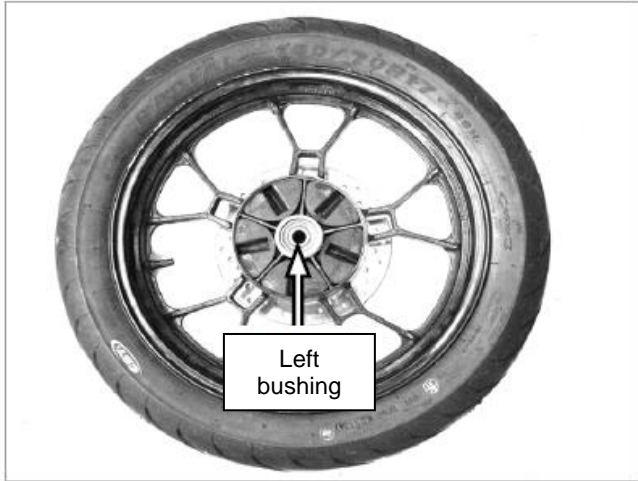

[7] Remove the rear axle lock nut and the rear wheel assembly. Remove the rear wheel left bushing and check the rear sprocket left bushing for wear.

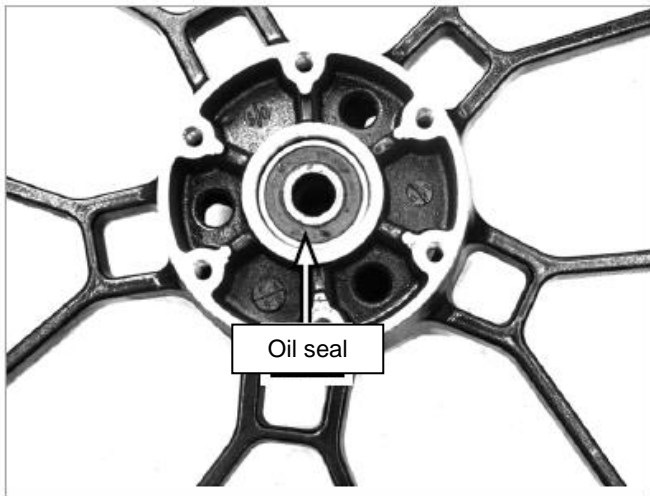

[8] Remove the rear drive sprocket oil seal and check whether the rear drive sprocket oil seal is worn.

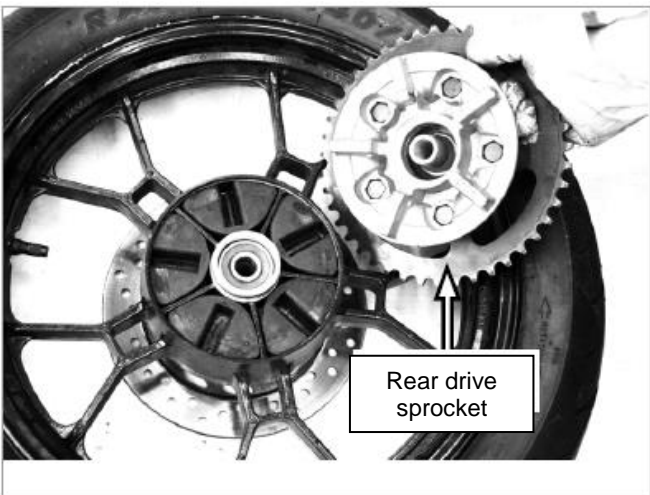

[9] Take out the rear drive sprocket and check the wear condition of the rear drive sprocket.

⚠ Caution

- When the large and small transmission sprockets are seriously worn, the large and small transmission sprockets and transmission chains shall be replaced in a complete set.

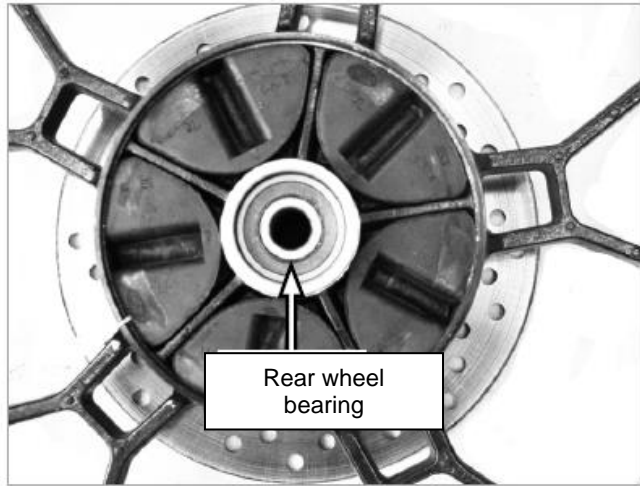

[10] Remove the inner bushing of the rear drive chain wheel and check the wear of the rear drive chain wheel bearing. When the bearing is worn, it should be replaced in time, otherwise it will affect the normal operation of the transmission system.

⚠ Warning

- When the rear drive sprocket bearing is worn, it should be replaced in time. Otherwise, the rear wheel will swing greatly or the rear wheel will become stuck.

III. Rear transmission device damage form, fault phenomenon and common maintenance methods are shown in table 3-5:

Table 3-5 Maintenance of rear transmission

Part name	Damage form	Component failure phenomenon	Vehicle failure phenomenon	Maintenance method
Driving sprocket	Excessive wear of gear teeth	Transmission chain tooth jump	The transmission chain makes abnormal noise, and the transmission chain is easy to fall off.	Replace the master-slave chain wheel and drive chain in a complete set.
	Excessive wear of spline teeth of gear teeth	Abnormal noise of transmission chain	The transmission chain is easy to fall off	Replace the master-slave chain wheel and drive chain in a complete set.
Driven sprocket	Excessive wear of gear teeth	Transmission chain tooth jump	The transmission chain makes abnormal noise, and the transmission chain is easy to fall off.	Replace the master-slave chain wheel and drive chain in a complete set.
	Excessive wear of spline teeth of gear teeth	Abnormal noise of transmission chain	The transmission chain is easy to fall off	Replace the master-slave chain wheel and drive chain in a complete set.
Drive chain	Too dirty or poorly lubricated		Drive chain drive abnormal noise	Cleaning and lubricating chain
	The chain is too tight.	Improper adjustment of chain tightness	Drive chain drive abnormal noise	Adjust the tightness of the transmission chain to 15 mm ~ 25 mm.
	The chain is too loose	Improper adjustment of chain tightness	The transmission chain transmits abnormal noise or chain jumping.	Adjust the tightness of the transmission chain to 15 mm ~ 25 mm.
	Excessive chain wear	Transmission chain tooth jump	The transmission chain is easy to fall off	Replace the master-slave chain wheel and drive chain in a complete set.
Transmission chain box	Damage to drive chain box		The transmission chain box is ringing	Replace drive chain box
Regulator	Improper adjustment of left and right regulators	The rear wheels tilt left and right	The transmission chain is easy to fall off	Re-adjust the left and right adjusters and ensure that the left and right scale lines are consistent
	Regulator damaged	The regulator cannot be adjusted	The transmission chain is easy to fall off	Replace regulator
Buffer rubber sleeve	The buffer rubber sleeve is seriously worn	Damaged buffer rubber sleeve	Abnormal sound of rear wheel drive	Replace the buffer rubber sleeve

Section 7 Frame and Subsidiary Organs

The frame is the supporting framework of the motorcycle and the main supporting part of the motorcycle. Because motorcycles are subject to strong road impact and vibration during driving, material selection and structure must require relatively high strength and rigidity, and at the same time, the weight of the frame must be relatively light, which is conducive to high-speed driving of motorcycles.

I. Structure and working principle of frame and subsidiary organs



The frame is a plate welded frame with a high strength, good rigidity and strong applicability. It mainly consists of the front section of the frame, the frame tail frame and the engine bracket.

The frame is mainly used to support the motorcycle engine, drive train system, control system, seat cushion, fuel tank, brake system, etc. At the same time, it also provides installation support points for other accessory mechanisms, making the motorcycle form a complete whole.

II. Disassembly and maintenance of frame and accessories

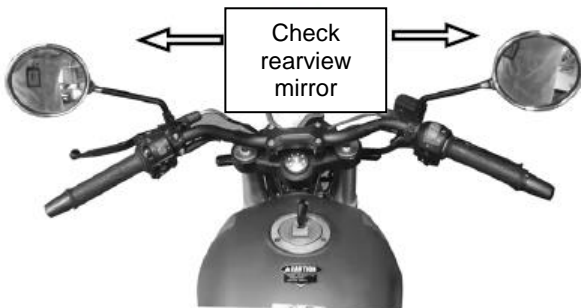

[1] Check whether the rearview mirror is loose or damaged. If the rearview mirror is loose or damaged, fix and replace the rearview mirror in time.

⚠ Caution

➤ Before driving the motorcycle, the rearview mirror must be kept clean and free of dust, and the rearview mirror must be adjusted to the best angle.



[2] Check whether the side bracket is bent or deformed, and replace or correct it when the side bracket is bent or deformed.

[3] Check whether the cover and seat cushion of the motorcycle are damaged, and replace them when the cover or seat cushion is damaged.

⚠ Suggestion

- If the cover or seat cushion is damaged, it should be replaced.



[4] Check whether the front pedal rubber sleeve is damaged, and replace it when the current pedal rubber sleeve is damaged.

⚠ Suggestion

- If the front pedal rubber sleeve is damaged, it should be replaced.

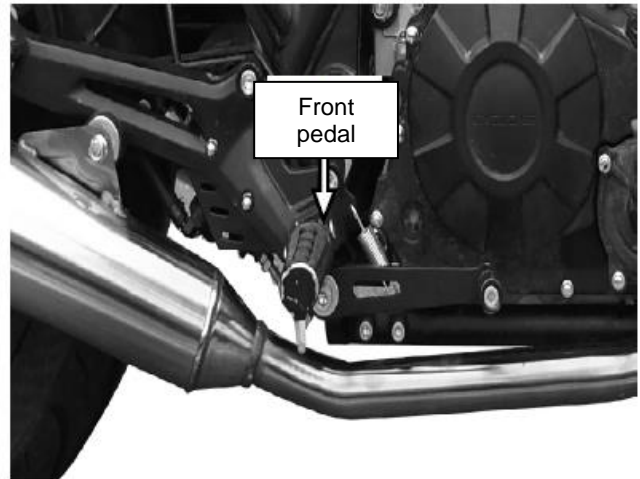

[6] Check whether there is looseness at the engagement between the shift pedal and the shift shaft, and also check whether the threads of the shift pedal adjusting rod are damaged.

⚠ Caution

- If the shift pedal does not return or cannot shift, check the engine shift control system.
- If the shift pedal is too high or too low, it should be adjusted at the shift pedal adjusting lever.

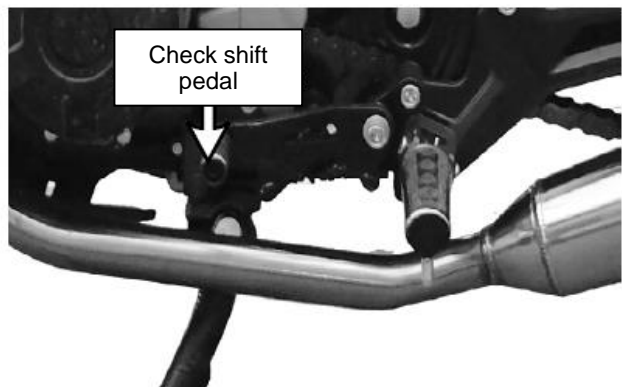

[6] Check the brake pedal for bending deformation.

⚠ Caution

- If the brake pedal is bent and deformed, it should be repaired or replaced.

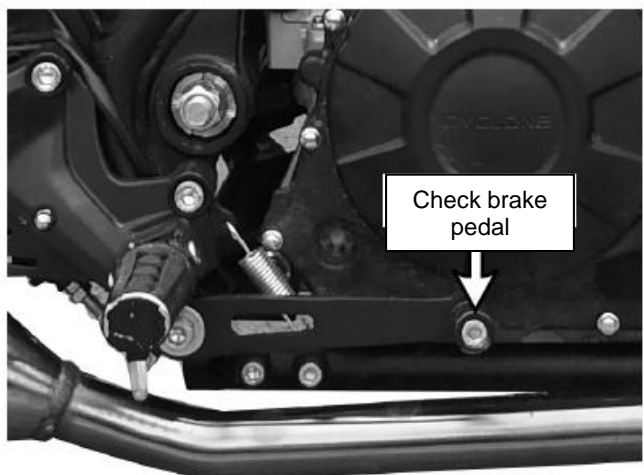

III. See Table 3-6 for the damage forms, failure phenomena and common maintenance methods of the frame and its accessories:

Table 3-6 Maintenance of frame and accessories

Part name	Damage form	Component failure phenomenon	Vehicle failure phenomenon	Maintenance method
Frame	Hit or fell down	Bent, deformed frame	Motorcycle runs in deviation.	To correct or replace the frame
	Hit or fell down	Cracked or broken frame	Motorcycles cannot run.	To weld or replace the frame
	Buffeted and shaken by the road	Frame welded off	The motorcycle shivered or ran off course	To weld the frame
Side bracket	Deformation or fracture	The side bracket is normal but cannot return	The motorcycle makes a loud noise, and affect parking	To correct or replace the side bracket
	The return spring loses elasticity	The side bracket is normal but cannot return	The motorcycle makes a loud noise, and affect parking	To replace return spring
Left cover	Damaged by impact	Broken left cover	The appearance gets damaged	To replace or repair the left side cover
Right cover	Damaged by impact	Broken right cover	The appearance gets damaged	To replace or repair the right side cover
Front fender	Struck or shaken	Deformation or damage	The motorcycle makes an abnormal noise	To replace the front fender
Rear fender	Struck or shaken	Deformation or damage	The motorcycle makes an abnormal noise	To replace rear fender
Front and rear seat cushions	_____	Damaged seat cushion leather cover	Comfort declines	To replace front and rear seat cushions
Front pedal	_____	Deformation damage	Danger increases	To replace the front pedal
Rear pedal	_____	Deformation damage	Comfort of seafarers	To replace the rear pedal
Foot pedal lever	_____	Deformation damage	Startup performance could be declined	To replace the kick rod
Rearview mirror	Struck or shaken	Deformation damage	Danger increases	To replace the rearview mirror

Section 8 Steering Mechanism

The steering of a motorcycle by a steering wheel. The steering handle is connected with the steering column, and the front shock absorber is rotated through the rotation of the steering column with the frame riser as the center to control the steering of the front wheel.

I. Structure and working principle of steering mechanism

[1] Handlebar

The right side of the motorcycle steering handle is the throttle knob to control the fuel flow, and the right-hand handle is the front brake handle. At the same time, left and right combination switches, rearview mirrors, choke switches, etc. are installed on the left and right handles of the direction.

[2] Direction column

The steering column is an important component of the motorcycle steering mechanism, which is mainly composed of steering column, lower coupling plate, bearing, bearing retaining ring, etc. The steering column and the lower connecting plate are welded together and are sleeved in the frame riser. The mass of the motorcycle and its passengers is transmitted to the front wheel through the direction column, and the impact load generated by the impact of the front wheel on the road surface is transmitted to the vehicle body through the direction column. Therefore, the steering column should not only bear a large impact load, but also ensure flexible rotation during driving

II. Disassembly and maintenance of steering mechanism

In order to maintain good operability of the vehicle, the steering mechanism should be maintained regularly. The steering mechanism shall be disassembled for a new car at 1500km and every 600km thereafter, and the wear of the inner and outer rings of the bearing and the balls shall be checked. If necessary, new parts shall be replaced. When replacing the ball bearings, they must be completely replaced and cannot be mixed with the old and the new.

The thrust bearing is the focus of inspection and repair of the direction column. If the bearing is lack of lubrication for a long time and the adjusting nut is loose, the bearing clearance will be too large, and the vehicle will shake seriously in the running direction, affecting the stability and safety of the vehicle. On the other hand, if the bearing is damaged or the adjusting nut is screwed too tightly, there will be a phenomenon that the rotation resistance is too large or even stuck in the direction, causing difficulties in operation and even out of control, affecting the driving safety.

Hold up the vehicle with the main bracket and suspend the front wheel. Shake the front fork or front shock absorber to check whether the bearing is loose. Turn the left and right direction knob to check whether the bearing is flexible. Both too tight or too loose bearings should be adjusted. Loosen the direction column lock nut first, check the tightness of the bearing while rotating the adjustment nut until it is normal, and then retighten the direction column lock nut.

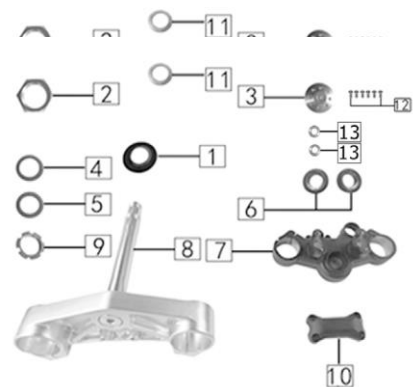

III. Steering column damage form, fault phenomenon and maintenance methods are shown in table 3-7:

Table 3-7 Maintenance of directional column

Part name	Damage form	Component failure phenomenon	Vehicle failure phenomenon	Maintenance method
Steel ball race	The adjusting nut is too tight	The fit clearance between the steel ball and the steel ball seat ring is too small	The steering handle is inflexible	Use a locking wrench to adjust the nut until the steering column rotates flexibly left and right and there is no feeling of axial movement between the steering column and the frame riser
	Excessive wear, pockmarks, pressure marks, cracks and damages of steel ball race raceway		The steering handle is inflexible, and the steering handle shakes or shakes during driving	Complete replacement of steel ball seat ring
Steel ball	Wear, deformation and damage		The steering handle is not flexible. The steering wobbles or shakes during driving.	To replace the whole set of steel ball
Direction column	Bent, deformed	Bent, deformed direction column	Driving deviation, inflexible turning handle	To correct or replace the steering column

Section 9 Control Wire Rope

I. Structure and working principle of the control wire rope

The control wire rope consists of wire rope, wire drawing head, metal spring plastic hose, etc. The steel wire rope shall be soft, not easy to break, and shall be made of multiple strands of fine steel wire. This not only ensures the strength of the wire rope, but also makes the wire rope very soft. Wire drawing head and wire rope are connected by soldering, punching and riveting, zinc alloy die casting and other methods. The outer layer of the metal spring plastic hose is plastic, and the inner layer is coiled with steel wires to form a spring-like flexible pipe, which not only adapts to multi-directional bending, but also can change the length when subjected to axial pressure. A layer of nylon sleeve is added between the metal spring plastic hose and the steel wire rope to avoid direct friction between the steel wire rope and the spring-like flexible pipe.

II Maintenance of control wire rope

In order to ensure that the operating wire rope can work reliably and prolong its service life, regular cleaning and lubrication are essential. The steel wire rope shall be cleaned and lubricated when the vehicle travels for 1500km for the first time and every 3000km thereafter. There are two ways: soaking lubrication and dripping lubrication.

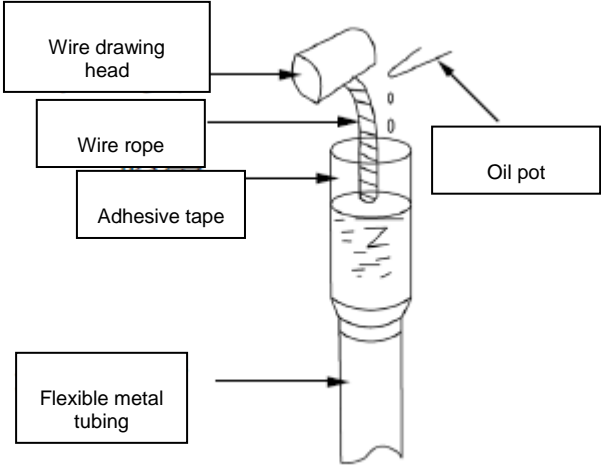
	<p>(1) Immersion lubrication</p> <p>The operation steps are as follows:</p> <p>[1] Soak the whole set of wire rope in kerosene for 5-10min, and pull the wire rope back and forth at the same time to clean the sundries in the hose.</p> <p>[2] Immerse the whole steel wire rope into the mixed oil prepared by kerosene and lubricating oil at a ratio of 1: 1 of 5min, and pull the steel wire rope back and forth to make the mixed oil flow into the hose.</p> <p>[3] Take out the control wire rope and wipe the mixed oil outside.</p>
 <p>Wire drawing head</p> <p>Wire rope</p> <p>Adhesive tape</p> <p>Oil pot</p> <p>Flexible metal tubing</p>	<p>(2) Drip lubrication</p> <p>The operation steps are as follows:</p> <p>[1] Wrap transparent tape around the end of the metal spring plastic hose of the wire rope and form a tube, as shown in the figure.</p> <p>[2] Raise the end wrapped with adhesive tape and pull out the drawing head.</p> <p>[3] Gently dip the oil into the hose with the oil can until it drips down the wire rope.</p>

III. Control system damage form, fault phenomenon and maintenance methods are shown in table 3-8:

Table 3-8 Maintenance of control system

Part name	Damage form	Component failure phenomenon	Vehicle failure phenomenon	Maintenance method
Handlebar	Bent, deformed	Handlebar bending deformation	Driving deviation	Correct or change direction handle
Clutch control cable	The wire rope is not flexible to pull in the wire rope jacket.	The clutch handle is laborious to operate or has poor return	Clutch slipping or incomplete clutch separation	Clean, lubricate or replace the control cable
	Broken wire rope	_____	The clutch is not completely disengaged	Replace the control cable
Rear brake pedal	Free travel is too small	_____	The brake shoe of the rear brake cannot return	Re-adjust the free travel
	Excessive free travel	_____	Rear brake failure	Re-adjust the free travel

Section 10 Shock Absorbers

The front shock absorber is an elastic connecting part between the front wheel and the vehicle body. The rear shock absorber mainly bears the axial force of the rear wheel of the motorcycle, and they jointly support the weight of the vehicle body. In that run process of the motorcycle, the impact and vibration of the front wheel and the rear wheel on the motorcycle rider are effectively and rapidly attenuated, the stress of various parts of the motorcycle is buffer, the service life of the motorcycle is prolonged, and the comfort, operability and stability of the rider are improved.

I. Structure and working principle of front and rear shock absorbers

[1] Front shock absorber

The motorcycle front shock absorber is a hydraulic spring composite front shock absorber, which mainly consists of a front shock absorber spring, a sealing ring, a dust proof cover, a piston ring, a front shock absorber column, a piston rod, a buffer spring, a one-way valve spring seat, a one-way valve spring, a one-way valve seat, a front shock absorber cylinder, a piston rod seat and the like.

When the front wheel of the motorcycle is impacted and vibrated by the road surface, when the front shock absorber cylinder ascends, the damping oil in the shock absorber flows upward through the one-way valve and the small hole on the piston rod, and the damping force is not large at this time; When the shock absorber cylinder continues to move upward, the gap between the cone surface of the one-way valve seat and the piston rod seat becomes smaller and smaller, thus increasing the damping and preventing the front shock absorber cylinder from colliding with the front shock absorber. When the front shock absorber cylinder descends due to the restoring force of the front shock absorber spring, the damping oil can only flow out of the small hole on the piston

rod due to the closing of the one-way valve, thus forming larger damping and effectively damping the vibration of the front shock absorber spring.

[2]

[2] Rear shock absorber

The motorcycle rear shock absorber is a hydraulic spring composite rear shock absorber, which mainly comprises an upper joint, a buffer rubber sleeve, a bushing, a rear shock absorber spring, a rear shock absorber rod, a piston, a damper, a lower joint and the like.

The rear shock absorber is mainly subjected to the axial force of the rear wheel of the motorcycle. When the rear wheel of the motorcycle is impacted and vibrated by the road surface, the hydraulic oil in the damper is forced to flow through the damping hole when the rear shock absorber is compressed and stretched, thus effectively damping the vibration of the rear shock absorber.

II. Disassembly and maintenance of front shock absorber

[1] Check the effective stroke and working performance of the front shock absorber, and check whether the front shock absorber leaks oil.

⚠ Caution

- When abnormal conditions occur to the current shock absorber, timely inspection and maintenance shall be carried out to ensure driving safety.

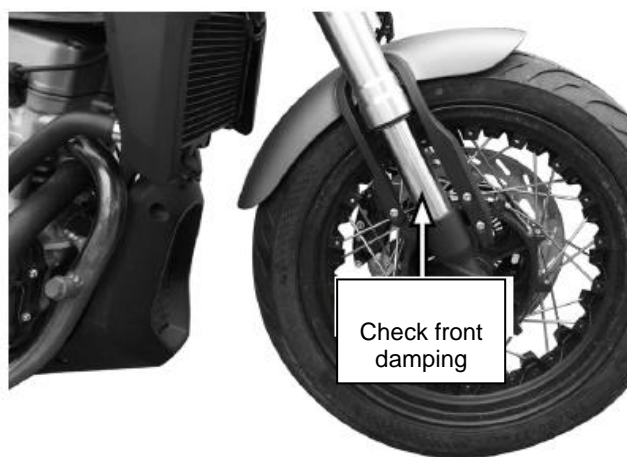

[2] Remove the front shock absorber fixing bolt and remove the front shock absorber.



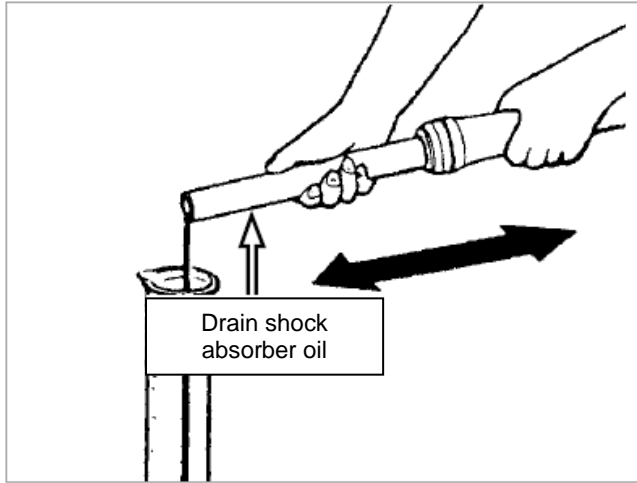

[3] Remove the front shock absorber drain bolt. Pour out the front shock absorber oil and check whether the front shock absorber oil is deteriorated. When the front shock absorber oil is deteriorated, replace the front shock absorber oil.

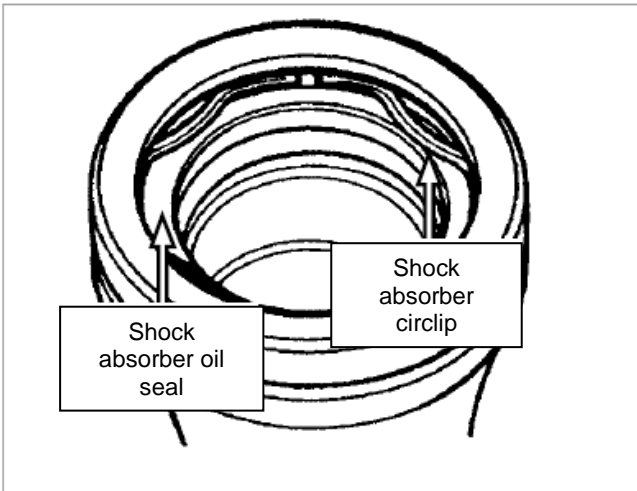

[4] Remove the front shock absorber oil seal and clamp spring, check whether the cutting edge of the front shock absorber oil seal is worn, and replace the front shock absorber oil seal.

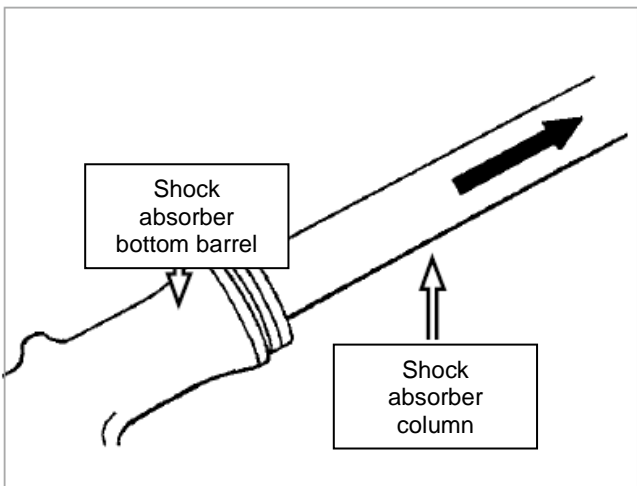

[5] Remove the front shock absorber column and the front shock absorber bottom cylinder, check whether the front shock absorber column and the front shock absorber bottom cylinder are worn, and replace the front shock absorber column and the front shock absorber bottom cylinder when they are worn.

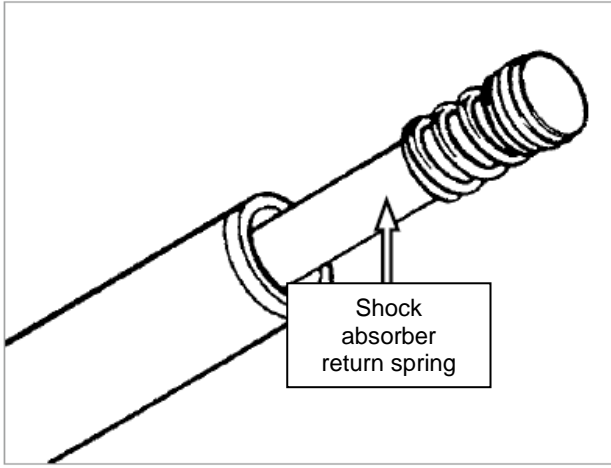

[6] Take out the return spring of the shock absorber column and check whether the elasticity of the return spring is worn or deformed, and replace it when the return spring is deformed.

[7] Use calipers to measure whether the inner diameter of the front shock absorber bottom cylinder exceeds the maintenance limit, and replace it when the inner diameter of the current shock absorber bottom cylinder exceeds the maintenance limit.

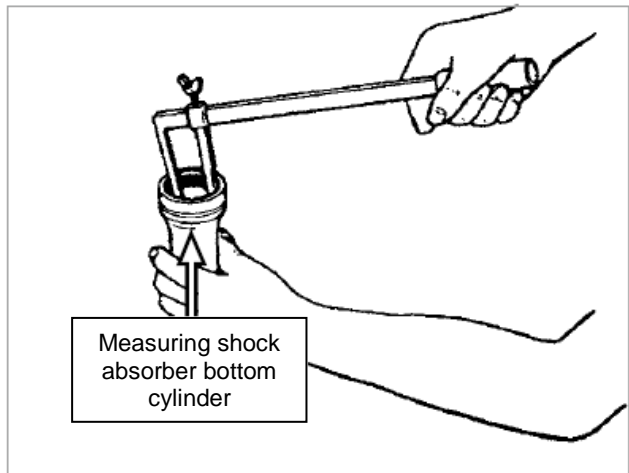

[8] Take out the front shock absorber return spring, check whether the front shock absorber return spring is worn, and replace it when the front shock absorber return spring is worn.

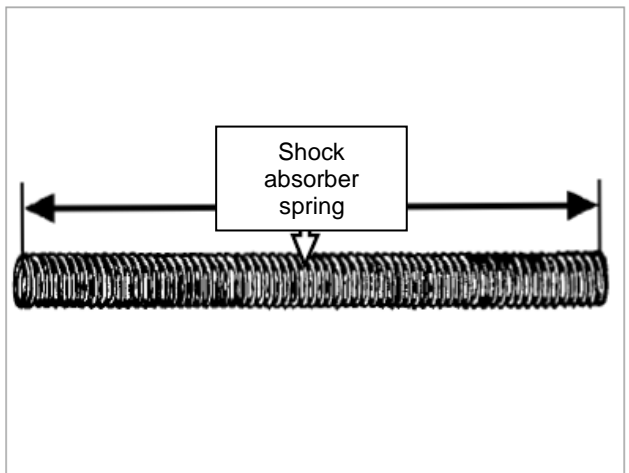

[9] When installing the front shock absorber, the front shock absorber oil must be filled according to regulations. The standard capacity of the front shock absorber oil is (3305) mL.

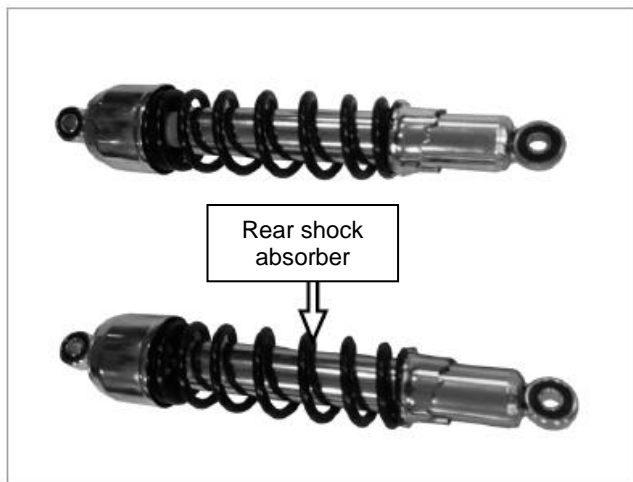
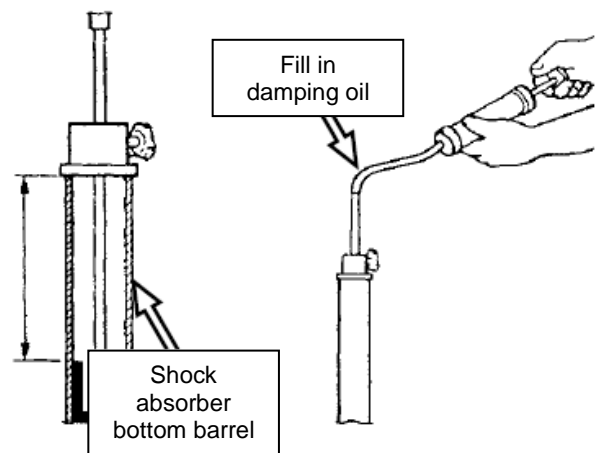

[2] Check whether the spring lengths of the left and right rear shock absorbers are consistent, check whether there is crack or damage on the spring surface of the shock absorber, and replace the rear shock absorber if necessary.

⚠ Caution

- When all rubber parts are damaged, worn or aged, new parts need to be replaced.

IV. Front and rear shock absorber damage form, fault phenomenon and common maintenance methods are shown in table 3-8:

Table 3-8 Maintenance of front and rear shock absorbers

Part name	Damage form	Component failure phenomenon	Vehicle failure phenomenon	Maintenance method
Front shock absorber	The front shock-absorbing spring has insufficient elasticity or is broken off	Front shock absorber too soft, front shock absorber damping abnormal sound	Driving comfort and stability and safety decline	Replace the front shock absorber or front shock absorber spring
	Bending deformation of front shock absorbing column	The left and right front shock absorbing columns are not on a horizontal line	Motorcycle's front wheel running deviation affects comfort, stability and safety	Correction and replacement of front shock absorption, correct and replace the front shock absorber
	The working stroke surface of the front shock absorber column is bruised or scratched.	Oil leakage at the front shock column oil seal	Driving comfort and stability and safety decline	Replace the front shock absorber or front shock absorber column
	The chrome coating on the working stroke surface of the front shock absorber column is partially worn to expose the metal part	Oil leakage at the front shock column oil seal	Motorcycle's front wheel running deviation affects comfort, stability and safety	Replace the front shock absorber or front shock column
	The front shock absorber bottom cylinder is seriously worn or rupture	Oil leakage from front shock absorber	Motorcycle's front wheel running deviation affects comfort, stability and safety	Replace the front shock absorber or front shock absorbing bottom cylinder
	Excessive wear of piston rod or damage	Front shock absorber too soft	Driving comfort and stability and safety decline	Replace front shock absorber or piston rod
	Excessive wear or damage to piston rings	Front shock absorber too soft	Driving comfort and stability and safety decline	Change the front shock absorber or piston ring
	Oil seal edge excessive wear or damage	Oil seal leakage, front shock absorber too soft	Driving comfort and stability and safety decline	Replace the front shock absorber oil seal
	Insufficient oil in front shock absorber or deterioration	Front shock absorber gets soft	Driving comfort and stability and safety decline	Add or replace as required Front shock absorber oil
Rear shock absorber	The rear shock absorbing spring is broken or its elasticity becomes soft.	Rear shock absorber gets soft	Motorcycle rear wheel running deviation, affect the comfort, stability and safety	To replace rear shock absorber
	Oil leakage from rear damper	Rear shock absorber gets soft	Driving comfort and stability and safety decline	To replace rear shock absorber
	The piston rod on the rear damper is bent, deformed or broken	Rear shock absorber bending deformation	Motorcycle rear wheel running deviation, affect the comfort, stability and safety	To replace rear shock absorber
	Wear or aging of upper and lower connecting rubber sleeves	The rear shock absorber is bent or rattled	Driving comfort and stability and safety decline	To replace upper and lower rubber sleeves

Section 11 Rear Fork

The rear fork of the motorcycle connects the rear wheel with the frame, and through the rear shock absorber, the rear wheel can swing up and down around a fixed point on the frame in a certain range to buffer the impact and vibration borne by the rear wheel.

I. Structure and working principle of rear fork

Because the rear fork is subject to greater impact and vibration from the rear wheel, it is welded by welding, riveting and other methods with relatively high strength and rigidity in material selection and welding. It is mainly composed of a rear fork, a dust seal, a dust seal cover, a bearing rear fork shaft sleeve and the like.

In order to ensure that the rear fork can swing up and down around the fixed center on the vehicle body, shaft sleeves or bearings are installed at the joint of the rear fork and the vehicle body, so that the rear wheel is more flexible and reliable when the rear fork swings.



II. Disassembly and maintenance of rear fork

[1] Check whether the rear fork is deformed or cracked due to external impact. Whether the fit clearance of the components of the rear fork is increased, and whether the left-right swing of the rear fork is too large.

 Caution

- In case of the above situation, please replace or repair the rear fork in time to ensure the comfort and safety of the vehicle.

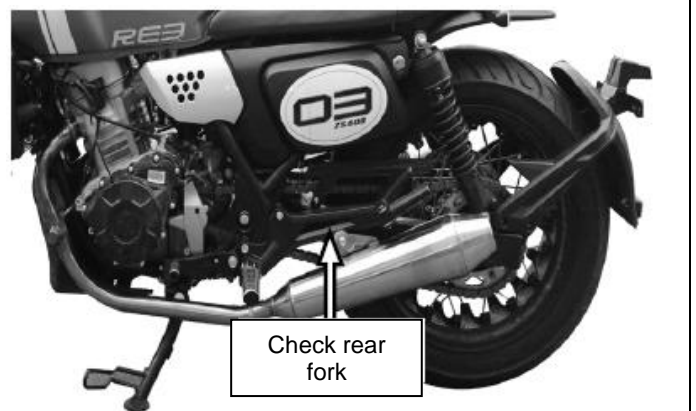

III. Rear fork damage form, fault phenomenon and common maintenance methods are shown in table 3-10:

Table 3-10 Maintenance of the rear fork

Part name	Damage form	Component failure phenomenon	Vehicle failure phenomenon	Maintenance method
Rear fork	The rear wheel was hit	Bending deformation of rear fork	Motorcycle's front wheel running deviation affects comfort, stability and safety	To correct or replace the rear fork
	The motorcycle rolls over and back fork gets broken	Rear fork fracture	Motorcycles cannot run normally	To weld or replace the rear fork
	The rear wheel is impacted and shaken too much	The rear fork welding off	Driving comfort and stability and safety decline	To weld the rear fork
	The motorcycle has poor road surface, and the rear wheels are impacted and vibrated too much.	The rear fork shaft sleeve is seriously worn due to dust seal	Poor sealing of rear fork shaft sleeve or bearing	To replace the dust seal of the rear flat fork shaft sleeve

Section 12 Wheels

The front and rear wheels are the running parts of the motorcycle, which support the quality of the whole car and ensure reliable adhesion to the road surface without slipping. The wheels can alleviate and absorb the vibration and impact caused by road. The front wheel is matched with the control part to determine the driving direction of the motorcycle. The rear wheel is powered by the engine to drive the motorcycle. Wheels are mainly composed of outer tires, inner tubes, aluminum wheels, hubs, bearings, bushings, oil seals, axles, etc.

I. Structure and working principle of wheels

[1] Tires

Tire is an important part of the walking system. Its function is to directly contact with the road surface, bear the mass of the whole vehicle, use its elasticity, alleviate the vibration and impact during driving, and ensure the balance of the vehicle, with reliable adhesion. Tires include outer tires, inner tubes and lining belts.

Outer tire

Outer tire consists of tread, carcass, buffer layer and bead. The tread of the outer tire is in direct contact with the road surface, and various tread patterns are made on the tread, so that the motorcycle can obtain proper adhesion on different roads. The tires should have certain strength, but it should not be too thick in order to enhance heat dissipation. Beads are made up of the edges of cord fabric, bead rings and wrapping, which makes the outer tire reliably fixed on the rim. The small circumference of the bead makes it difficult to disassemble and assemble the outer tire. If the circumference is too large, the outer tire will jump out easily. The ply is the skeleton of the outer tire, and the plies in the outer tire cross each other and form an angle (crown angle) with the cross section of the tire. However, the cords in radial tires are arranged in the radial direction of the earth, and the crown angle is 0. Radial tires have the advantages of reducing power loss, saving fuel, and long service life.

Inner tire and lining belt

The inner tire is made of rubber and is annular. It is equipped with an air valve through which the air pressure inside the inner tube can be adjusted. The amount of air pressure in the inner tires is the main factor affecting the use of wheels and tires, and the main index of the inner tire is air tightness. The lining belt is an annular rubber belt, which separates the inner tires from the rim, protects the air tightness of the inner tires and prevents the inner tires from being punctured by sharp protrusions.

[2] Rim

Rim is the framework for supporting and fixing tires. The rim is in two configurations: die-cast rim and spoke rim. Die-casting rim is formed by casting aluminum alloy into a whole by pressure casting, and then machining. This kind of rim has high strength, simple process and convenient assembly, but its elasticity is poor and cannot be adjusted. If it is deformed or damaged, it needs to be replaced as a whole. Spoke rim is made of rolled steel strip. There are several hole seats on the circumference of the rim. One spoke and spoke nut are installed in each hole seat. The other end of the spoke is connected with the hub. It has good impact resistance, easy adjustment and maintenance. This section takes die-cast rim as an example to explain.

[3] Wheel hub

The wheel hub of motorcycle is divided into front wheel hub and rear wheel hub. The structures of the front and rear hubs are basically similar, but because the rear wheels are driving wheels, a power transmission structure is added to the rear hubs. Bearings, bearing bushes, oil seals, wheel shafts and the like are installed in the front and rear hubs, which is beneficial to the normal movement of the hubs.

II. Disassembly and maintenance of wheel

 <p data-bbox="272 1559 466 1630">Check front tires</p>	<p data-bbox="794 1171 1473 1330">[1] Check whether the tire pressure is kept within the normal pressure range, remove foreign matters in the tread pattern of the outer tire, maintain the adhesion between the tire and the ground, and prevent sharp objects from damaging the inner and outer tires.</p> <p data-bbox="794 1402 927 1435">⚠ Caution</p> <p data-bbox="794 1458 1473 1525">➤ Check the abrasion of the outer tire, and replace it if it exceeds the maintenance limit: 2.00 mm.</p>
--	--

[2] If the front wheel of the motorcycle is vibrated or deformed due to impact, running deviation or shaking or swaying of the steering handle during running, the wheel must be replaced or adjusted.

⚠Caution

- When the wheel runout exceeds the service limit, replace the wheel.



[3] Before removing the front wheel, the motorcycle body must be fixed firmly to keep the front wheel off the ground, then remove the front wheel axle fastening nut, take out the front wheel axle, and take down the front wheel assembly.



[4] Take out the front axle bushing and check the wear of the front wheel bushing. If the front wheel bushing is seriously worn, it should be replaced.

⚠Caution

- Lubricating grease should be applied when installing bushings.

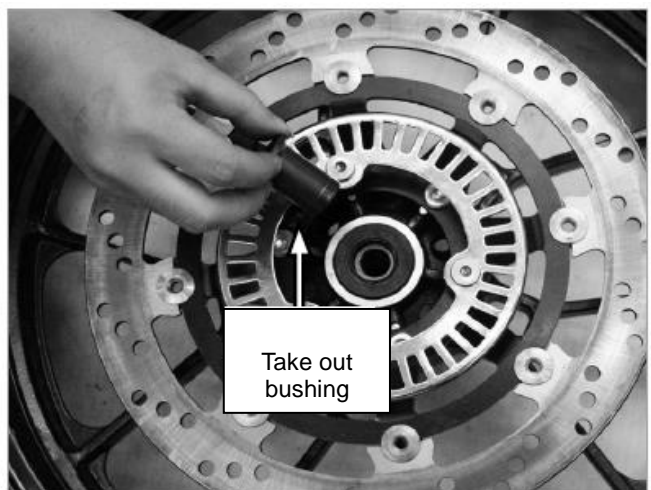

[5] Take out the front axle oil seal and check the wear condition of the front wheel oil seal cutting edge. If the front wheel oil seal cutting edge is seriously worn, it should be replaced.

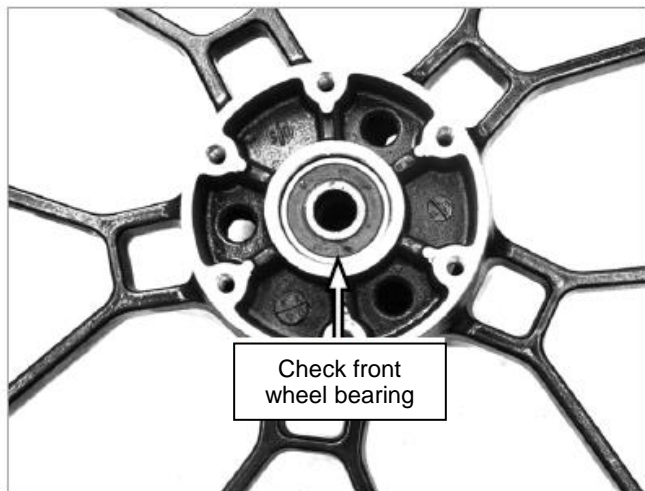
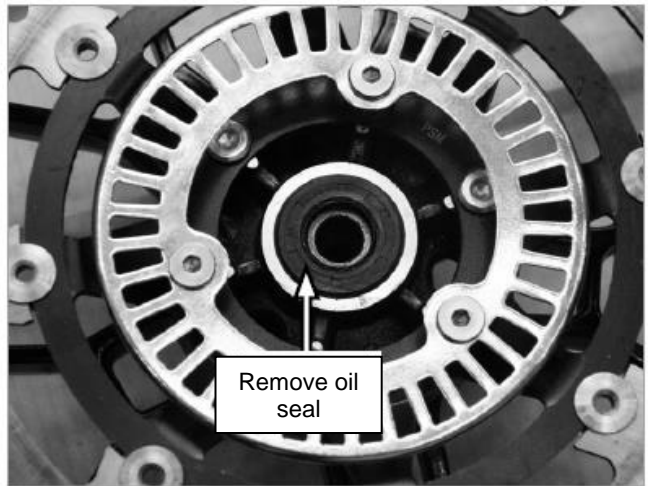

[6] Place the front wheel on the calibration table, rotate the front wheel at high speed by hand, and check the wear and free travel of the front wheel axle. Check whether the front wheel bearing is worn. When the front wheel bearing is worn, the front wheel bearing needs to be removed for replacement.

⚠ Caution

- If you hear noise or the free travel is too wide, you must replace the bearings. When installing, the bearing shall be coated with lubricating grease and the bearing oil cover shall be installed outwards.

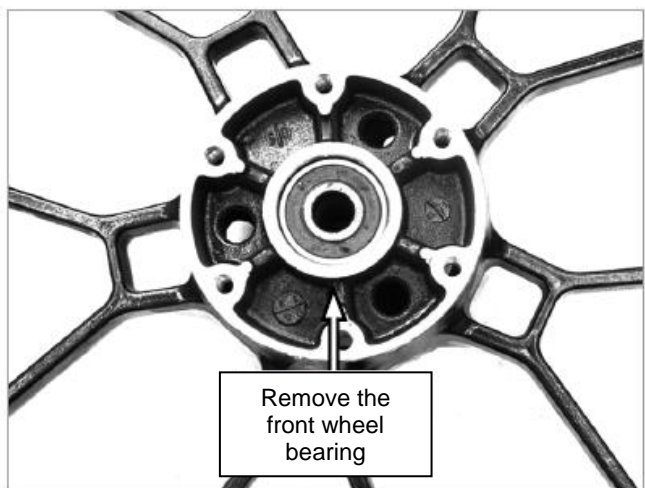

[7] If the front wheel bearing is seriously worn and damaged, the front wheel bearing shall be knocked out gently with the axle bearing removal tool and replaced with a new bearing.

⚠ Caution

When installing the front wheel bearing, the bearing must be coated with grease and the bearing oil cover must be installed outwards.

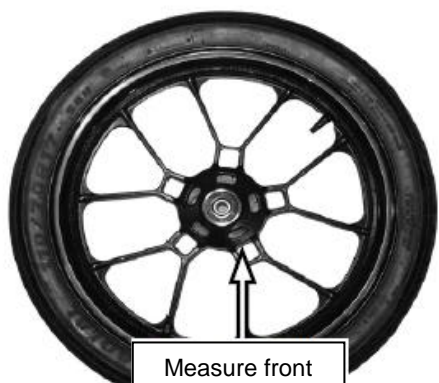

Measure front wheel yaw

[8] Place the front wheel on the calibration table, check the deflection of the front wheel, rotate the front wheel by hand, measure the deflection value of the front wheel with a dial indicator, and read the deflection value shown.

Maintenance limit: radial 2.0mm

Axial direction 2.0mm

⚠ Caution

- If the front wheel yaw exceeds the above maintenance limit of 2.0m m, the front wheel shall be corrected or replaced.



Check the front wheel casing

[9] Check the wear condition of the front wheel tread. The repair limit value of the tread wear of the front wheel tread is 2.00mm. During the use of motorcycle, if the front tire pressure is insufficient, first check the inner tube valve core for air leakage, and then check the inner tube for air leakage.

⚠ Caution

- If the valve core of the tire leaks, the valve core must be repaired or replaced. If the valve core of the inner tire leaks, the inner tire must be repaired or replaced.

[10] Remove the rear axle lock nut, take out the rear axle, and take down the rear wheel assembly.

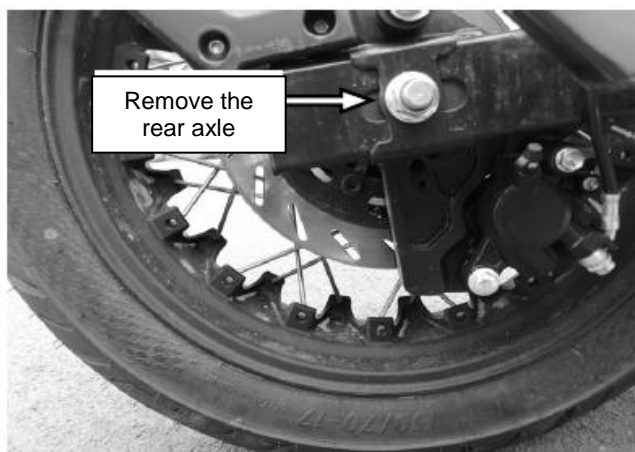

Remove the rear axle

[11] Remove the rear wheel, check the rear hub for damage, and replace it when the rear wheel hub is damaged.

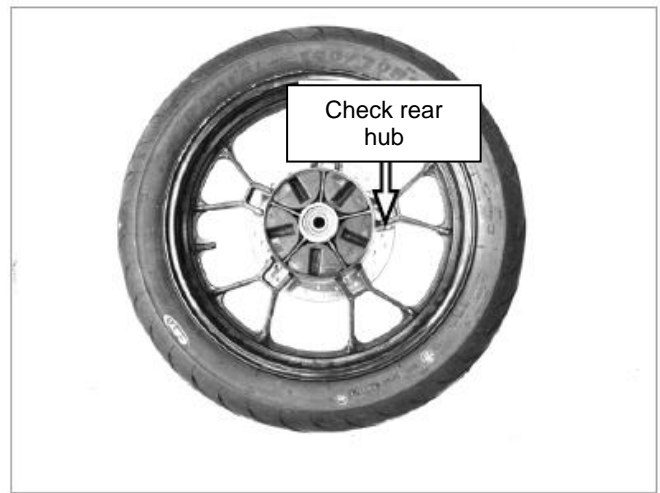

[12] Check whether the rear wheel bearing is worn. When the rear wheel bearing is worn, the rear wheel bearing shall be removed for replacement.

⚠ Caution

➤ Grease should be applied during installation.

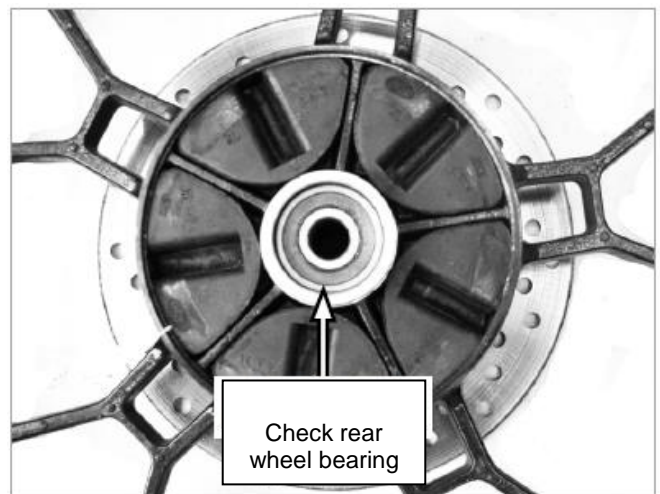

[13] Check whether the front and rear aluminum wheels are deformed, timely correct the front and rear aluminum wheels or replace the aluminum wheels. Check whether the tread pattern of the rear wheel is worn. When the tread pattern of the rear wheel is worn beyond the maintenance limit of 2mm, the rear wheel tread needs to be replaced.

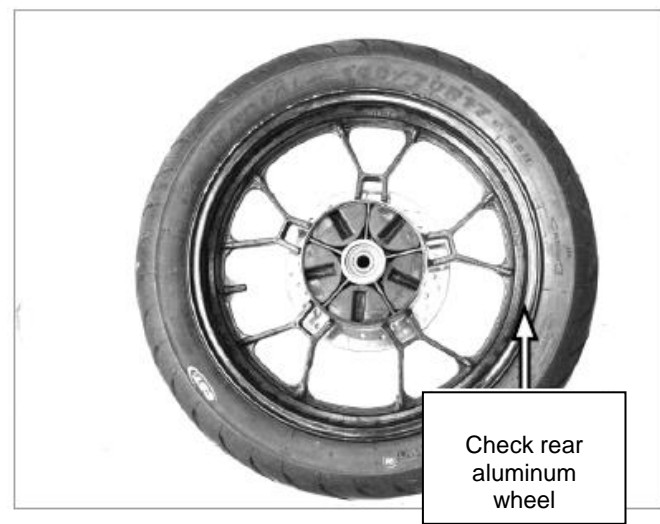

III. Wheel damage form, fault phenomenon and common maintenance methods are shown in table 3-11:

Table 3-11 Maintenance of wheels

Part name	Damage form	Component failure phenomenon	Vehicle failure phenomenon	Maintenance method
Front wheel	Front wheel distortion	Front wheel distortion	Running deviation, the steering handle shakes or shakes during running	To replace the front wheel
	Excessive wear of hub bearing seat hole	The hub bearing seat hole is loose due to the fit with the bearing	Running deviation, the steering handle shakes or shakes during running	
	Bearing is excessively worn or damaged.	The axial and radial clearance between the inner and outer rings of the bearing is too large or the rotation is inflexible	Running deviation, the steering handle shakes or shakes during running	To replace the bearing
Front tire	Excessive wearing	_____	Slippery when driving and poor anti sideslip ability	To replace the outer tire
Odometer gear box	Gear damage		The odometer pointer does not rotate	To replace the speedometer gear box
	Damage to gear ring		The odometer pointer does not rotate	To replace the speedometer gear box
Rear wheel	Rear wheel distortion	Distortion of rear aluminum wheel	Driving deviation, rear wheel swinging during driving	To replace the bearing
	Rear wheel broken	_____		
	Excessive wear of hub bearing hole	The hub bearing seat hole is loose due to the fit with the bearing		
	Bearing is excessively worn or damaged	The axial and radial clearance between the inner and outer rings of the bearing is too large or the rotation is inflexible		
Rear tire	Excessive wearing	_____	Slippery when driving and poor anti sideslip ability	To replace the outer tire

Section 13 Brake

Motorcycles often need to slow down and stop during driving, which requires the brake to apply a force or moment to prevent the wheels from rotating so as to achieve the purpose of slowing down or stopping. The normal motorcycle has the right hand to control the front wheel brake and the right foot to control the rear wheel brake. In some vehicles with automatic clutch engines, such as mopeds or scooters, the rear wheel brakes are operated by the left hand. Motorcycle brakes can be divided into drum brakes and disc brakes. This motorcycle is a front and rear disc brake.

I. Structure and working principle of brake

Disc brakes are divided into mechanical type and hydraulic type. At present, hydraulic disc brakes are mostly used on motorcycles. Hydraulic disc brake is generally composed of brake handle (brake pedal), brake master cylinder, storage cylinder (front brake intermediate storage cylinder and brake master cylinder are generally integrated), brake caliper, brake disc, brake oil pipe, etc. When the brake is applied, the brake handle compresses the main oil cylinder, causing the pressure in the hydraulic system to rise, pushing the main piston in the brake caliper, and pressing the friction plate against the brake disc, so that the brake disc fixed on the wheel obtains the braking torque. The disc brake is characterized by soft operation, automatic cleaning and difficult failure.



Structure diagram of disc brake

II. Disassembly and maintenance of brake

[1] Hold the front brake handle with your right hand to check the braking performance of the front brake. The standard free stroke of the front brake grip is 10mm ~ 20mm.

⚠ Caution

➤ If the front brake handle cannot reach the standard value of 10mm~20mm, the front brake must be readjusted.

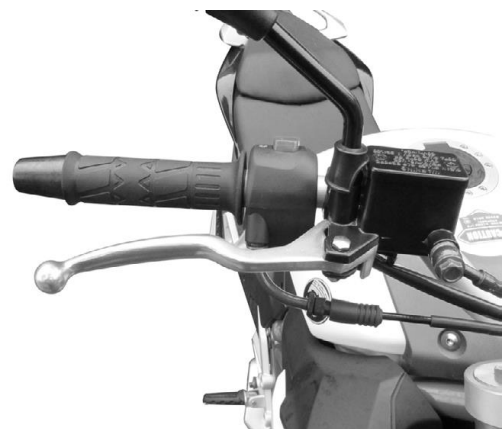

[2] Remove the front brake caliper locking bolt and remove the front brake caliper.

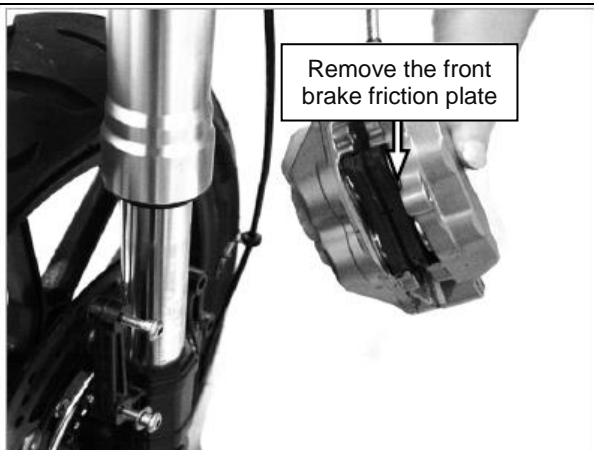
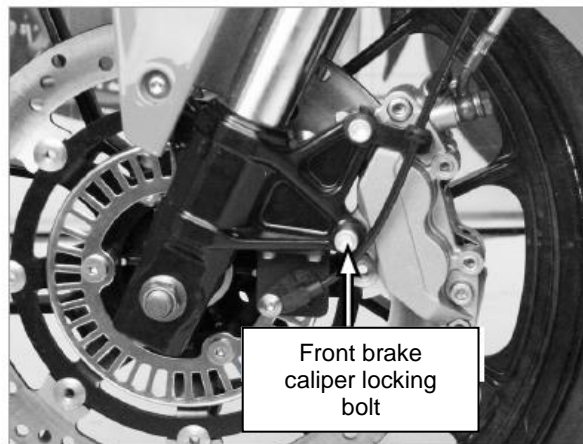

[3] Remove the disc brake friction plate and check the working condition of the brake caliper piston. If the brake caliper piston cannot operate normally, the hydraulic brake must be repaired or replaced.



[4] Remove the fastening nut of the front axle, the soft axle of the mileage line and the front wheel.

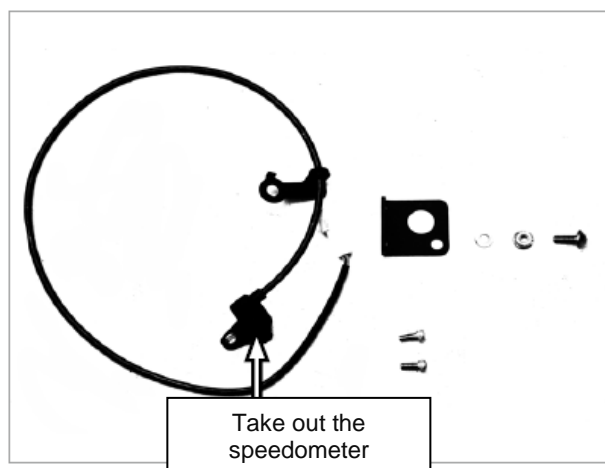

[5] Take out the speedometer and check whether the oil seal edge of the speedometer is worn or damaged. If the oil seal edge of the speedometer is worn or damaged, it should be replaced.

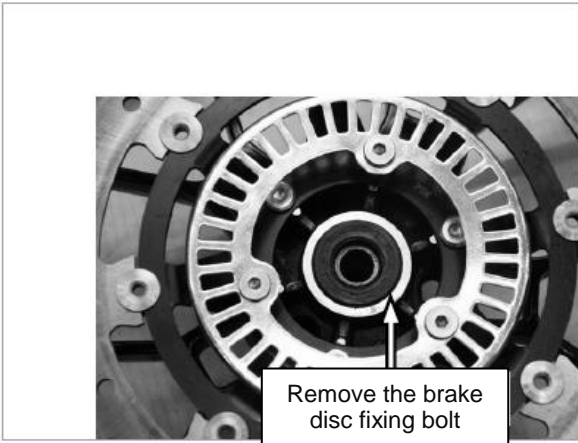

[6] Remove the front wheel, remove the front brake disc fixing bolt, and take out the front brake disc.

 Warning

➤ When installing the front brake disc, stop glue must be coated on the bolt to prevent the bolt from loosening.

[7] Measure the thickness of the front brake disc with a micrometer. The maintenance limit is 2.0 mm.

 Caution

➤ If the brake disc thickness exceeds the service limit of 2.0mm, it should be replaced.

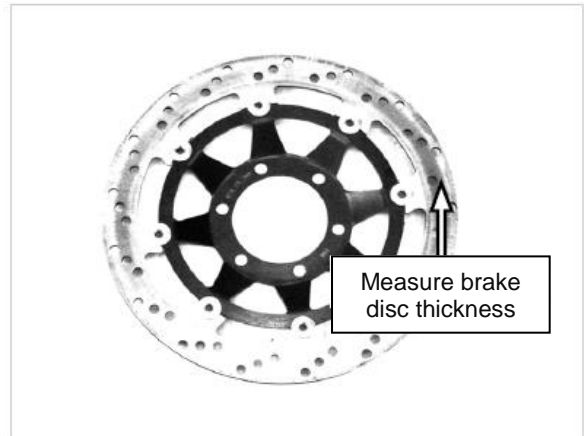

[8] Measure the runout of the front brake disc with a dial indicator, and its maintenance limit value is 0.3 mm.

 Caution

➤ If the brake disc runout exceeds the service limit: 0.3mm, it should be replaced.

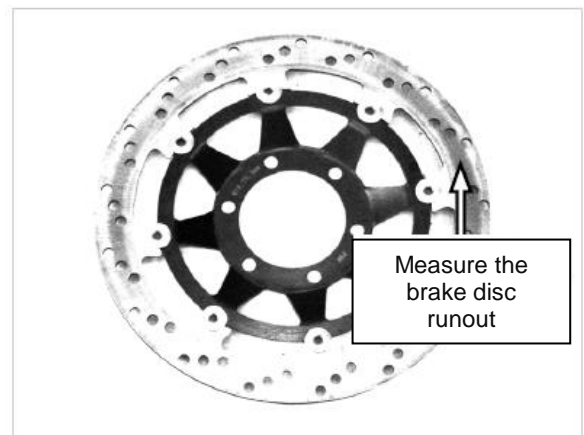

[9] Check whether the rear brake pedal can return normally, whether the free stroke of the rear brake pedal is too large or too small, and adjust the free stroke of the rear brake pedal to 20 mm ~ 30 mm.

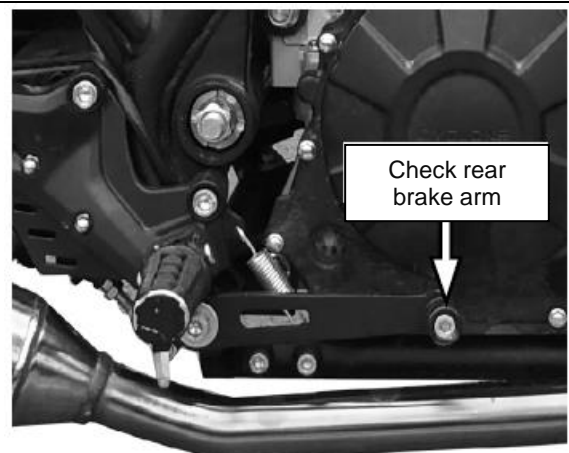

[10]

[10] When the free stroke of the rear brake pedal is too large or too small, adjust the free stroke of the rear brake pedal by adjusting the rear brake lever nut at the brake lever.

[A] 20mm~30mm

[A] Adjust the rear brake adjusting nut to adjust the free stroke of the rear brake pedal to 20 mm ~ 30 mm.

[B]

[B] Pedal the rear brake pedal several times, then release the rear brake pedal and rotate the rear wheel assembly to check whether the rear wheel can rotate freely.

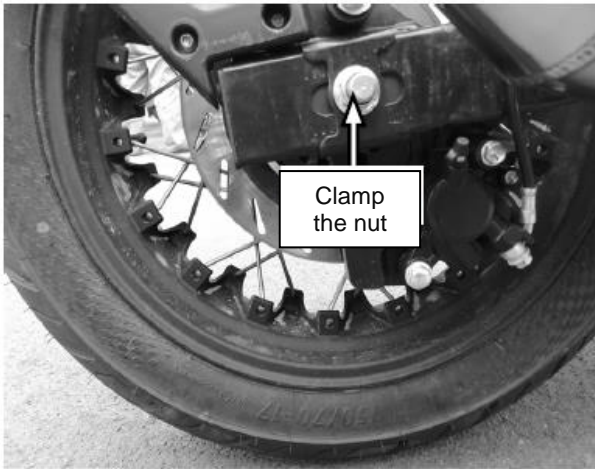
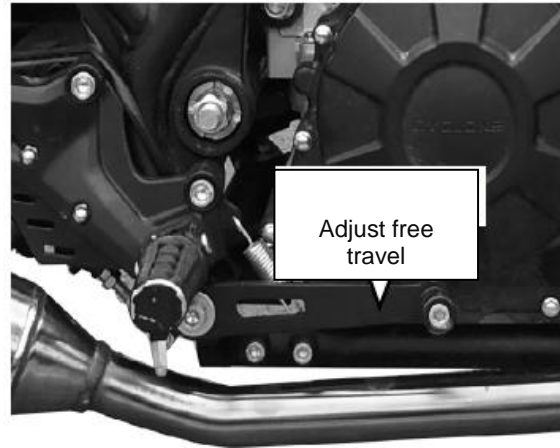

[11] Remove the rear axle nut and take out the rear axle and rear wheel assembly.

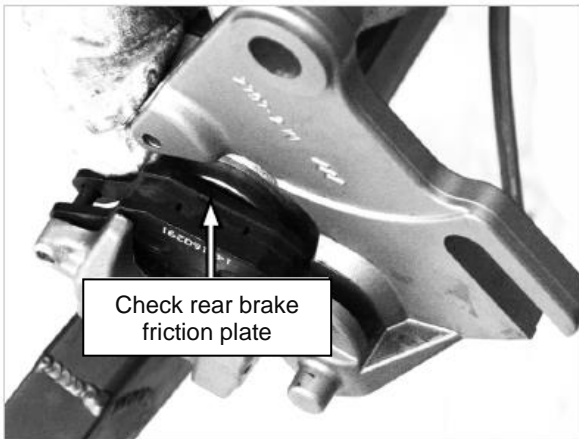

[12] Remove the friction plate of the rear brake and check the wear condition of the friction plate. Its maintenance limit is 2.0 mm.

Check the working condition of the brake caliper piston. If the brake caliper piston cannot operate normally, the hydraulic brake must be repaired or replaced.

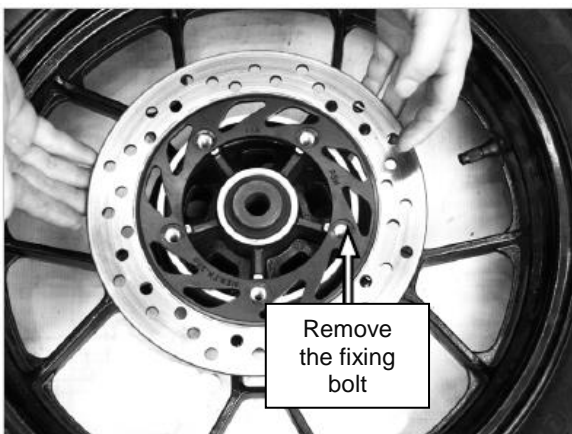

[13] Remove the rear brake disc fixing bolt and take out the rear brake disc.

 Warning

➤ When installing the rear brake disc, stop glue must be coated on the bolt to prevent the bolt from loosening.

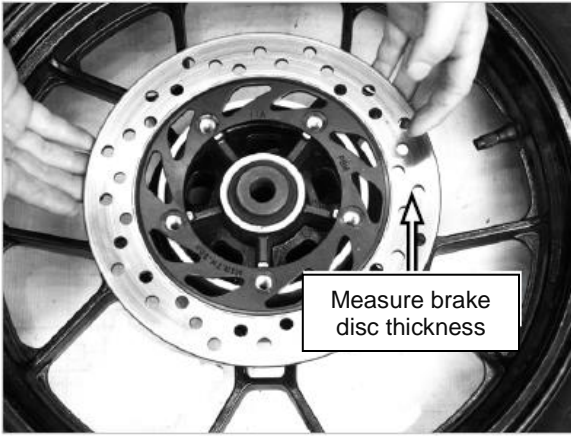

[14] Check the wear of the rear brake disc.

131.0mm

Measure the inner diameter of the rear brake drum with caliper, and its maintenance limit value is 131.0mm

⚠ Caution

- If the inner diameter of the rear brake drum exceeds the maintenance limit value of 131.0mm, the rear aluminum alloy wheels should be replaced.

[15] Measure the brake disc runout with a dial indicator, and its maintenance limit value is 0.3 mm.

⚠ Caution

- 0.3mm,
- If the brake disc runout exceeds the service limit: 0.3mm, it should be replaced.

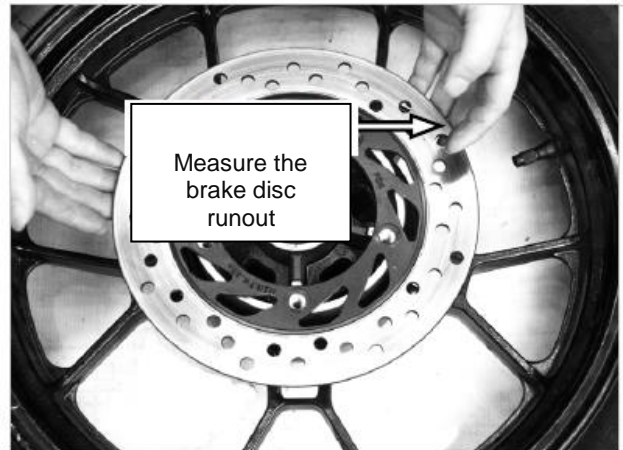

III. Front and rear brake damage forms, fault phenomenon and maintenance methods are shown in 3-12:

Table 3-12 Maintenance of Front and Rear Brakes

Part name	Damage form	Component failure phenomenon	Vehicle failure phenomenon	Maintenance method
Brake shoe	Excessive wear of friction plates		The brake fails or the brake shoe cannot return	To replace brake shoes in complete sets
	The end face of the brake shoe is worn into a groove or excessively worn by the brake convex wheel.		Abnormal sound or failure of rear brake during braking	
	The contact area between the brake shoe and the brake drum is too small		Brake failure	File or replace brake shoe friction plate
	The spring force of brake shoe is insufficient or broken		The brake shoe cannot return	To replace return spring
Brake cam	The moving parts are rusted or	The brake cam does not rotate	Brake failure or failure to return	Clean and lubricate the brake protrusion.
	Wear of brake cam arc surface		Brake failure	Replace the brake cam

Section 14 Instruments

The motorcycle meter shows the working condition of the motorcycle.

I. Structure and working principle of instrument

[1] Speedometer

The speedometer shows the current running speed and accumulated mileage of the motorcycle. The speedometer is driven by the front wheel. The rotating speed of the front wheel is transmitted to the speedometer through the speed change mechanism by the flexible shaft, so that the magnetic cylinder rotates. The eddy current disk cuts the magnetic lines, generates eddy current and magnetic field, and interacts with the magnetic field of the magnetic cylinder, so that the eddy current disk receives a torsion moment, overcomes the resistance of the balance spring, and drives the pointer to rotate. The higher the vehicle speed, the stronger the magnetic field of the eddy current disk, the greater the torsion moment, the greater the deflection angle, the greater the deflection angle of the pointer, and the higher the pointing speed on the panel. At the same time, the rotating spindle drives the counter through the worm wheel and worm, and the counter displays the accumulated mileage of the motorcycle.

The speedometer shall be maintained once a year, and lubricating oil shall be added to the parts to be lubricated.



[2] Fuel Meter

The fuel gauge shows the amount of oil in the fuel tank. The fuel gauge refers to the change of resistance in the sensor caused by the change of fuel level height. The lead is introduced into the oil level indicator and the change of oil level is displayed through the oil level indicator.

ii. the instrument disassembly and maintenance

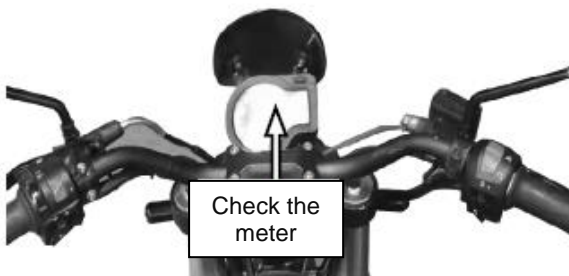

[1] When each indicator of the meter cannot work normally, the mileage meter shall be removed for inspection.

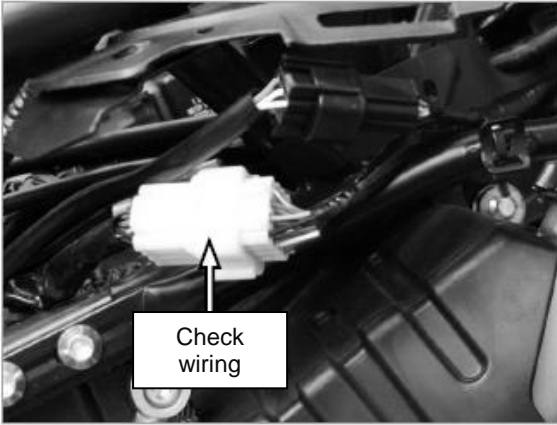

[3] Check whether the instrument wiring is loose.

III. Instrument damage form, fault phenomenon and common maintenance methods are shown in table 3-13:

Table 3-13 Maintenance of the instrument

Part name	Damage form	Component failure phenomenon	Vehicle failure phenomenon	Maintenance method
Instrument assembly	The lamp filament of the indicator lamp is burnt out	The lamp filament of the indicator lamp is burnt out	The indicator light is not on	Replace the indicator lamp bulb
	Filament of instrument lighting lamp is burnt out	Filament of instrument lighting lamp is burnt out	The instrument lights are not on	Replace the bulb of instrument lighting lamp
	The speedometer is damaged	The speedometer is damaged	The speedometer does not work	Replace speedometer

Chapter IV Electricity and Gas Division

Section 1 Basic Knowledge

In order to deeply understand the structure and working principle of motorcycle electrical system, we must first have a clear concept of some basic electrical knowledge.

I. Electricity, current, voltage and resistance

The basic component of any substance is an atom. There are positively charged nuclei and negatively charged electrons in the atom. The two keep a balance in the amount of charge and the positive and negative cancel each other out, thus making the atom neutral to the outside. Once the object is affected by external factors, such as friction and magnetic field, the balance will be broken, thus increasing or decreasing the movement of electrons. At this time, the object is charged because the atom is no longer neutral. The nature of the charge is related to the increase or decrease of the number of electrons. When the number of electrons increases, the object is negatively charged and when the number of electrons decreases, the object is positively charged.

Charge moves regularly in a conductor along a certain direction, which is called current. Usually, the intensity of current is measured by the amount of charge per unit time. Electrically, it is expressed by I , its intensity unit is A, and its symbol is A. It is generally stipulated that the direction of current flows from the positive electrode to the negative electrode of the battery.

Since there is an interaction force between electric charges, it is necessary to do work to overcome this force in order to move the electric charges. The work done to overcome the attraction force between electric charges when moving the positive charges is called potential, and the potential difference between any two points is called voltage, expressed by U , and the unit is V.

When a current flows in an object, the object will generate a certain resistance to it. This resistance is called electric resistance, expressed by R , and its unit is Ω . Objects made of different materials have different resistances. Metals such as copper, iron and aluminum have smaller resistances and are called conductors. However, wood, ceramics, plastics and other materials have great electrical resistance and are called insulators. There are also some objects (such as silicon) whose conductivity is between the two and are called semiconductors.

II. Ohm's law

Ohm's law reflects the relationship among voltage, resistance and current, i.e. current I is proportional to voltage u and inversely proportional to resistance R . The formula is: $I=U/R$, which can also be changed to: $U=IR, R=U/I$.

III. Electrical equipment, direct current and alternating current, power supply

The so-called electrical equipment, that is, the usual load, refers to equipment that can consume electrical energy and convert electrical energy into other forms of energy.

The device that supplies the electrical energy needed by the electrical equipment is called power supply, also called power supply equipment.

There are two forms of current provided by the power supply for electrical equipment: one is that its size and direction do not change with time, and this current is called direct current; While the other has its magnitude and direction changing periodically with time. This current is called alternating current.

IV. Circuit, series circuit and parallel circuit

A closed circuit composed of power supply, electrical equipment and connecting wires is called a circuit. The circuit has two basic forms: a series circuit and a parallel circuit. In the series circuit, several electrical equipment are connected end to end without any bifurcation in the middle. At this time, the current through each electrical equipment is the same. In the parallel circuit, the voltages at the two ends of each electrical equipment are the same before they are connected end to end at the same two points. In the more complicated motorcycle circuit, series circuit and parallel circuit often exist at the same time.

V. Short circuit and open circuit

In a normal circuit, if the two wires from the power supply to the electrical equipment are directly connected to each other without passing through the electrical equipment, this phenomenon is called short circuit. In the circuit composed of power supply, electrical equipment and connecting wires, the current cannot form a closed circuit due to the disconnection of the wires. This phenomenon is called open circuit.

VI. Left hand rule and the right hand rule

In the magnetic field that produces electromagnetic induction, stretch out your left hand, flatten your palm, make your thumb perpendicular to the other four fingers, make the magnetic lines of force pass through your palm vertically, and point your four fingers in the direction of the current. At this time, the direction pointed by your thumb is the direction of the magnetic field force, which is called the left-hand rule.

Straighten the thumb of the right hand and hold the coil with the four fingers along the current direction, then the direction pointed by the thumb is the magnetic line direction of the magnetic field generated by the energized coil. It is called the right-hand rule.

As an important component of motorcycle, the structure and function of the electrical system directly affect the performance and riding of motorcycle. The electrical system is divided into three parts. Namely a power supply part, a control part and a power consumption part. Since the ignition system in the electrical part is the core part of the motorcycle, the ignition system is specially placed in the engine part for description. In the process of daily use, users should often carry out maintenance on the electrical system. Common faults of motorcycle electrical system mainly depend on the electrical schematic diagram to find out, so the company usually attaches the electrical schematic diagram of the motorcycle in the motorcycle operation and maintenance manual and the appendix of the motorcycle maintenance manual.

Section 2 Power Supply

The power supply part is generally composed of two main components: a magneto (generator) and a storage battery. Its main function is: in the motorcycle's own closing circuit, the magneto and the storage battery supply current to the electricity consuming part of the electrical system through parallel operation, and store the surplus electric energy in the storage tank.

I. Structure and working principle of power supply

The power supply part is generally composed of two main components: a magneto (generator) and a storage battery. Its main function is: in the closed circuit of the motorcycle itself, the generator and the storage battery supply current to the electricity consuming part of the electrical system through parallel operation, and store the surplus electric energy in the storage tank.

Generators can be divided into direct current generators and alternating current generators according to the nature of their output currents. According to different structures, AC generators can be divided into flywheel type AC generators, magnet rotor type AC generators and three-phase AC generators. The magnetic poles in the first two kinds of generators are permanent magnets, so they are also called permanent magnet AC generators. The latter is to turn on the coil to generate magnetic poles, so it is also called excitation AC generator. In general, we often say that magneto refers to flywheel alternator.

Battery can be divided into 6V battery and 12V battery according to rated voltage. Batteries with the same rated voltage can be divided into many types from large to small according to capacity. According to different structures, they can be divided into lead-acid batteries and fully sealed maintenance-free batteries.

[1] Structure and principle of DC magneto

DC magneto works according to the principle of electromagnetic induction, that is, when the wire moves in a uniform magnetic field perpendicular to the magnetic field lines, induced electromotive force will be generated in the wire, and if the wire and other external circuits form a closed loop, induced current will be generated in the wire, and the direction of the current will be judged by the right-hand rule.

[2] Structure and principle of AC magneto

Structure and Principle of AC Magneto Generator The alternator mainly includes flywheel type alternator, magnet rotor type AC magneto and three-phase AC magneto. Machine, magneto is also using electromagnetic induction principle to work. However, it does not use the conductor to move perpendicular to the magnetic lines in a uniform magnetic field to generate current, but the rotor made of permanent magnets rotates continuously to form a rotating magnetic field, which makes the magnetic lines alternate intermittently through the fixed coil, thus generating induced alternating current.

[3] The Structure and working principle of battery

The battery has the advantages of light weight, small volume, good sealing performance and anti-vibration performance, and the lead-acid battery also has the advantages of small internal resistance and stable voltage. It mainly consists of a shell, a shell cover, polar plates, electrolyte and separators. The shell is made of hard rubber or plastic with acid resistance, heat resistance and vibration resistance, and is divided into 3 or 6 independent parts which are not communicated with each other according to the rated voltage of the storage battery. The shell is generally marked with upper and lower engraved lines, the upper engraved line is marked with "H" and the lower engraved line is marked with "L", indicating the upper limit and lower limit of the storage battery. At the same time, the storage battery is also marked with positive and

negative marks, with "+" being the positive pole and "-" being the negative pole.

Polar plates are the main working substances for charging and discharging chemical reactions of storage batteries. They are made of lead antimony alloy grid coated with active substances after electrochemical treatment. Polar plates are divided into positive and negative plates. The active substance on the positive plate is lead dioxide PbO_2 , and the active substance on the negative plate is spongy pure lead Pb .

Electrolyte is a mixture of special sulfuric acid and distilled water. The standard measuring temperature of electrolyte density is 20. Under the condition of standard temperature and fully charged battery, its density is generally between $1.24 \sim 1.29 \text{ g/cm}^3$. A group of polar plates and electrolyte are arranged in each independent part of the shell, and each group of polar plates respectively react with the electrolyte to form an independent single cell. The voltage is about 2V. Three or six single cells are connected in series, i.e. a storage battery with a rated voltage of 6V or 12V is formed. The shell cover is made of hard rubber or hard plastic with high insulation performance and forms a complete internal space with the shell.

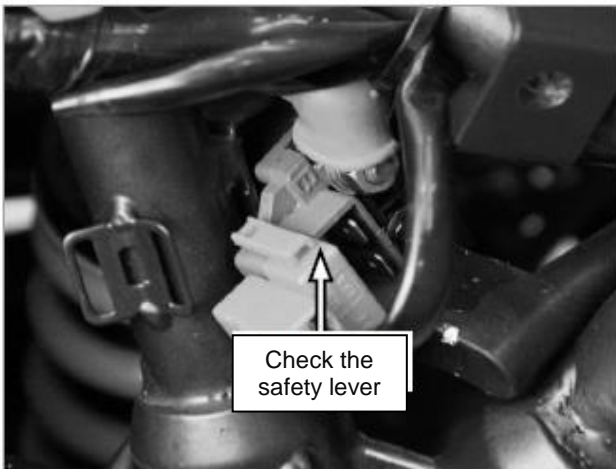

II. The power supply part of the disassembly and maintenance

[1] Take out the safety lever, check whether the safety lever is fused, and replace the safety lever of the same model.

Type of safety piece: 12V/20A

⚠ Caution

- When the safety lever is damaged, replace the safety lever of the same model.

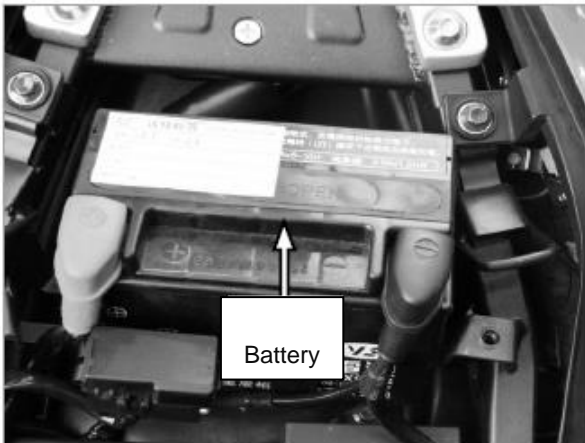

[2] Take out the storage battery and use a multi meter to measure whether the voltage at both ends of the storage battery is above "12V". When the voltage of the storage battery is below "12V", the storage battery needs to be taken off for charging.

⚠ Caution

- Tighten the connecting bolt when the battery terminal bolt is loose.
- When the electrolyte level of the storage battery is lower than the lower limit scribing line, distilled water shall be filled in time.
- Keep away from the fire source when charging the battery, because flammable and explosive gases will be released during charging.

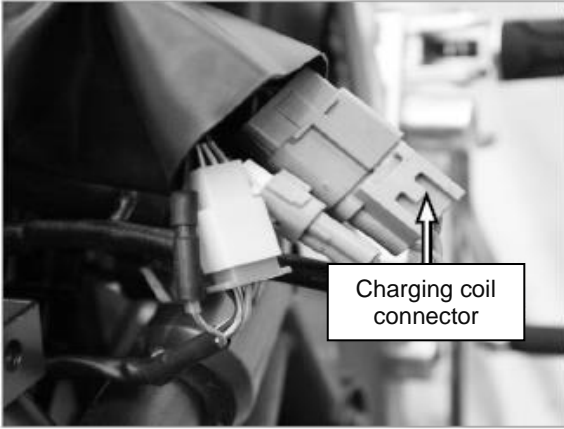

[3] Remove the magneto charging coil socket, and use a multimeter to measure whether the magneto charging coil is short-circuited. When the magneto charging coil is short-circuited, replace the magneto charging coil.

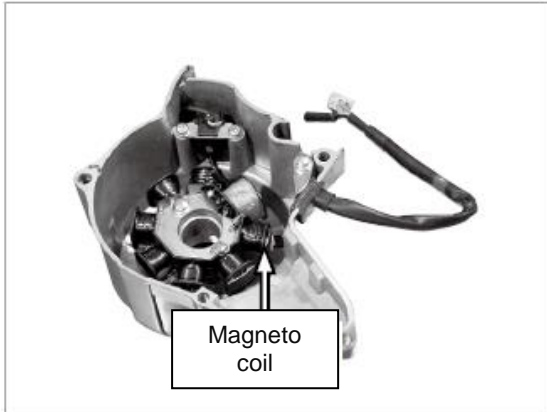

[4] Remove the engine left box cover, take out the magneto stator, and use a universal meter to measure whether the magneto stator resistance is short-circuited or open-circuited. If the magneto stator resistance is short-circuited or open-circuited, replace the magneto stator.

[5] Check whether the magnetic cylinder of the magneto rotor is demagnetized, and replace the magnetic cylinder when the magnetic cylinder of the magneto rotor is demagnetized.

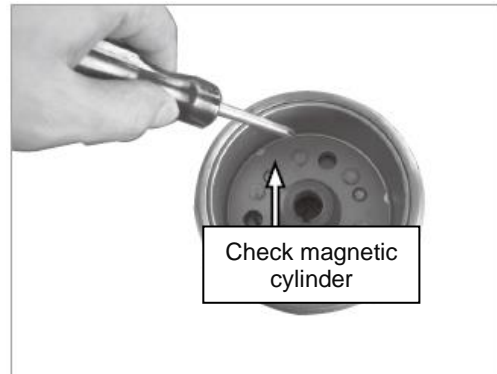

III. Power supply part of the damage form, fault phenomenon and common maintenance methods are shown in table 4-1:

Table 4-1 Maintenance of Power Supply Parts

Part name	Damage form	Component failure phenomenon	Vehicle failure phenomenon	Maintenance method
Charging coil	Short circuit	Battery power is low.	Headlamps are not on, the engine is difficult to start, the engine power is insufficient, and the engine idle speed is unstable.	To replace charging coil
	Open circuit (resistance)	No spark jumps out between spark plug electrodes	The engine cannot start	
Magneto rotor	Deformation	Magneto has no current output or low output current	The engine is difficult to start or cannot be started, and the power consumption devices of the whole vehicle cannot work normally due to insufficient power	To replace magneto rotor
	Demagnetization	Magneto has no current output	The engine cannot start and the headlights do not turn on	
Battery	Battery damaged	No electricity	The starting motor does not rotate	To replace the battery
	Long time storage	Insufficient electricity and low voltage	The starting motor does not rotate or is unable to rotate, and the signal system does not work properly	Replenish distilled water or replace battery
	Insufficient electrolyte	Insufficient electricity and low voltage	The starting motor does not rotate or is unable to rotate, and the signal system does not work properly	To replenish distilled water or replace battery
Safety lever	Damaged or blown	No electricity	The starting motor does not rotate	Replace the safety lever

Section 3 Control Section

I. Composition and function of control section

In the electric system of the motorcycle, the control part ensures the normal work of the power supply part and the power consumption part respectively and the harmony between them. And the driver can control the electrical system at any time.

The control part mainly includes the regulator, rectifier, flash relay, starting relay, fuse, control switch and cable assembly, etc.

(I) Regulator

Regulator is an important control element in the power supply part of motorcycle electrical system. According to different generator forms, it can be divided into two types: DC generator regulator and AC generator regulator.

[1] DC generator regulator

Because the output voltage of the DC generator regulator is proportional to the speed, it will bring some problems: [A] When the vehicle runs at high speed, the engine speed is high, and the output voltage of the connected DC generator is very high, which will easily burn out the electrical equipment and overcharge the battery. [B] When the vehicle is running at low speed, the engine speed is relatively low, thus causing the battery to discharge to the DC generator with large current and burn it down. Therefore, it is necessary for the regulator and generator to work together.

[2] Alternator regulator

In motorcycles equipped with magneto, in addition to using rectifier to convert AC generated by magneto into DC, AC regulator is also needed to stabilize the output of magneto. Currently, the most commonly used AC regulators are all electronic AC regulators.

The AC regulator consists of transistors, diodes and thyristors. When the magneto works, its lighting and signal coils generate AC

(II) Rectifier

Common rectifiers can be divided into two types: single-phase half-wave rectifiers and full-wave bridge rectifiers. Both rectifiers work by utilizing the unidirectional conductive characteristics of silicon diodes. It is like an electronic valve that allows current to pass in only one direction.

(III) Flash relay

Flash relays are also called scintillators and are commonly used in three types: thermal resistance type, capacitive type and transistor type.

(IV) Start relay

When the starting motor works, the current is very large, reaching several tens of amperes.

The starting relay is actually an electromagnetic switch. When the start switch on the right handle is pressed, the current passes through the battery, battery terminal, relay coil, start switch terminal and start

switch, and then is grounded to form a loop.

(V) Fuse

Fuses generally consist of fuse tubes that are encased in plastic fuse boxes.

(VI) Control switch

Each control switch of the electrical system is concentrated on the left and right hand handles. Generally, there are far and low beam dimming switches, turn signal switches and horn switches on the left hand handlebar from top to bottom. The right hand handle has a position lamp, a headlight switch and an electric starting switch from top to bottom. There is also a circuit master switch in the center of the handle.

(VII) Main cable

All parts of the motorcycle's electrical system are connected into a whole by wires. In order to prevent all kinds of wires from being tangled together in disorder and to facilitate arrangement on the frame, wires in the same direction are often bundled with insulating tape, which is the cable assembly.

. The control part of the disassembly and maintenance

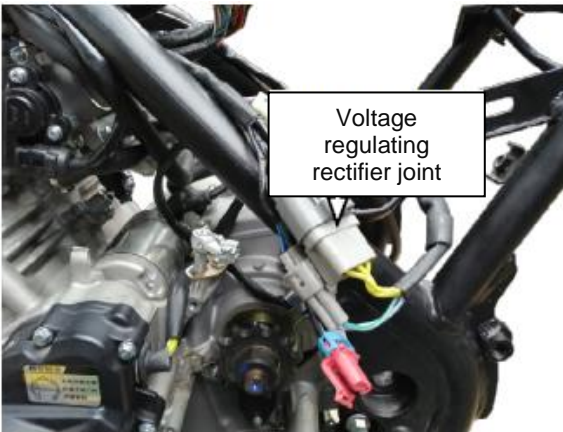

[1] Use a multi meter to measure whether the output voltage of the voltage regulating rectifier is within the range of 13.0V ~ 14.0 V. When the output voltage of the voltage regulating rectifier is lower than 13.0 V, the voltage regulating rectifier needs to be replaced.

⚠ Caution

➤ When the radiating fin of the voltage regulating rectifier is damaged, the voltage regulating rectifier shall be replaced.

[2] Remove the flasher socket of the signal system and use a multimeter to measure whether the flasher is short-circuited, and replace it when the flasher is short-circuited.

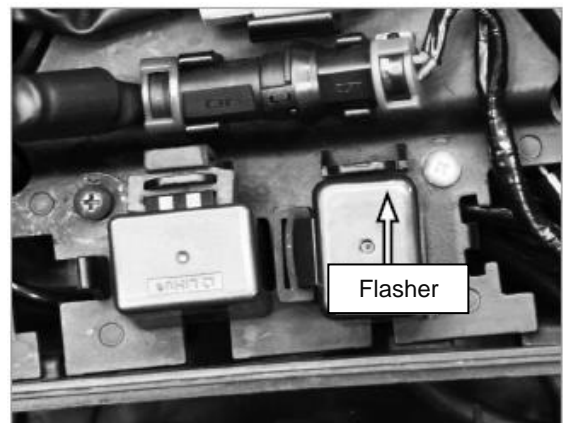

[3] Check whether the starting relay works normally. When the starting relay cannot work normally, replace the starting relay of the same model.

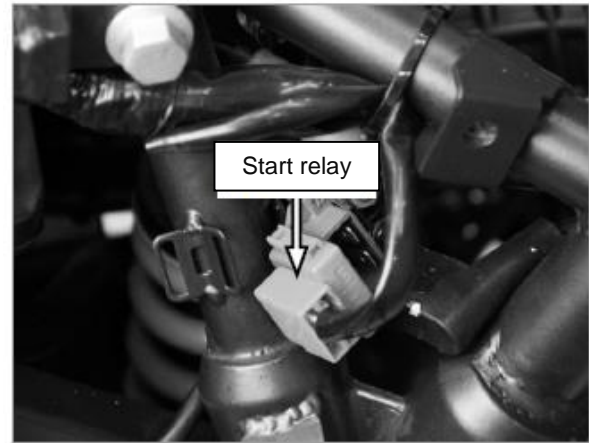

[4] Remove the left and right combination control button switches, check whether each control button switch is short-circuited or damaged, and repair or replace each control button on and off.

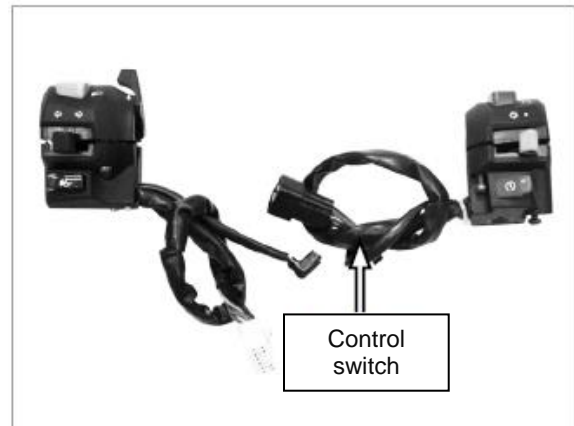

 Caution

- Check whether the front and rear brake light switches work normally. When the brake light switch cannot work normally, the brake light switch needs to be readjusted and replaced.
- If the front and rear brake lights do not illuminate during braking, there will be no electric starting.

[5] Take out the fuse tube, check whether the fuse tube is fused, and replace the fuse tube with the same type number.

Safety tube model: 12V/20A

 Caution

- When the fuse is damaged, replace the fuse of the same model.

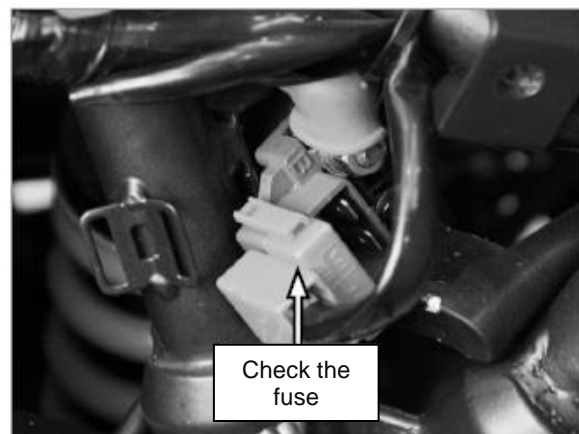



[6]

[6] Check whether the main cable is damaged. When the insulation tape of the main cable conductor is damaged, it shall be bound in time.

III. Control part of the damage form, fault phenomenon and common maintenance methods are shown in table 4-2:

Table 4-2 Maintenance of control part

Part name	Damage form	Component failure phenomenon	Vehicle failure phenomenon	Maintenance method
Rectifier	Damaged	Rectifier voltage regulator open circuit or short circuit	The battery is not charged, the lighting lamp is weak or doesn't work, and the lighting lamp is easy to burn out	To replace rectifier voltage regulator
Start relay	The internal coil short circuit or open circuit	The starting motor does not work	The vehicle cannot be started electrically	To replace the start relay
	Internal contact ablation	The starting motor is unable to rotate		
Start button	Poor or damaged internal contacts	The starting motor does not work	The vehicle cannot be started electrically	To replace the button
	Internal contact ablation	The starting motor does not work or is unable to rotate	The vehicle cannot be started electrically	To check the battery
Safety lever	Damaged or blown	No electricity	The starting motor does not rotate	Replace the safety lever
Lighting/Dimming switch	Poor or damaged internal contacts	Poor or damaged internal contact	Lighting lamp does not work normally or does not work	To repair or replace the lighting/dimming switch
Turn signal switch	Poor contact of the internal contact	Poor or damaged internal contact	The turn signal is not on	To repair or replace the turn signal switch
Flasher	Internal burn-out	The flasher burned out inside	The turn signal does not illuminate or flash	To replace the flasher
Brake lamp switch	Internal contact does not return or damage	Brake light switch does not return or is damaged	The brake light is on or off for a long time	To repair or replace the brake light switch
Horn button	Poor or damaged internal contacts	Poor or damaged internal contact of horn button	The klaxon does not sound or does not sound normally	To repair or replace horn button

Section 4 Electricity Consumption

The power consumption part of motorcycle electrical system mainly consists of the following components:

(I) Lighting signal device

Lighting signal devices include headlights, position lamp, tail lights (license plate lights), instrument lights, etc. Its main function is to provide lighting for drivers and remind other vehicles to pay attention when driving at night to ensure driving safety.

The signaling device includes steering indicator, horn, gear indicator, brake light, etc. It is used to indicate the driving state of the vehicle to the driver and relevant personnel, and to express the driver's operation intention through acoustic and optical signals.

(II) Electric starting device

The electric starting device comprises a starting motor, an engaging mechanism and the like, and is mainly used for starting an engine. (See Chapter II, Section 7 for details)

I. Lighting signal device

(I) Headlights and position lamp

Headlights can illuminate the road in front of the driver, making it easy to identify various road conditions and vehicles on the way, and can send signals to oncoming people and vehicles, and can also express overtaking intention to the vehicles in front by flashing headlights. When driving in foggy weather, headlights are often turned on to ensure driving safety.

Position lamp is used to mark the location of vehicles when meeting at night or when driving in urban areas with better lighting conditions to remind others to pay attention. It is usually installed in the headlamp assembly.

Headlamp mainly includes condenser, glass cover, bulb, lamp holder, lamp mouth cover and shell.

The function of the condenser is to effectively concentrate the light emitted by the bulb to form a light beam with higher brightness, which is mainly made of

The main function of the glass cover is to diffuse the light beam reflected by the condenser, so as to ensure that there is enough area in front of the road for uniform illumination, so as not to make the drivers who come to the car feel dizzy.

Bulbs can be divided into single filament bulbs and double filament bulbs.

The lamp holder is generally stamped from galvanized iron sheet and is cylindrical, with 3 uneven lugs on the edge and holes are made at the bottom through which wires

The lamp mouth cover and the shell form a complete space to accommodate other parts of the headlamp.

(II) Tail lights and brake lights

The taillight is used to show the position of the vehicle to the rear when driving at night and to make the license plate number clearly visible.

The rear tail lamp is mainly composed of lampshade, lamp shell, lamp holder and bulb. The lampshade is made of red plexiglass, and a transparent plexiglass window is embedded in the lower part, so that the license plate can be illuminated by the light.

The lamp housing is also made of plastic, and the two sides of the bottom are respectively provided with supports with round holes, and the lampshade can be connected with the lamp housing by screws.

(III) Horn

During the driving process, the motorcycle driver can make the electric horn sound through switch control to remind passers-by and other vehicles to pay attention, so as to ensure the driving safety.

Electric horn can be divided into AC horn and DC horn according to different power supply modes. This car is a DC horn.

(IV) Turn signals

When the motorcycle needs to turn, the flashing relay can make the steering lamp emit a yellow flashing signal to remind others that the motorcycle is about to turn. Turn signal lamp generally includes four parts: lamp shell, lamp holder, bulb and lamp shade.

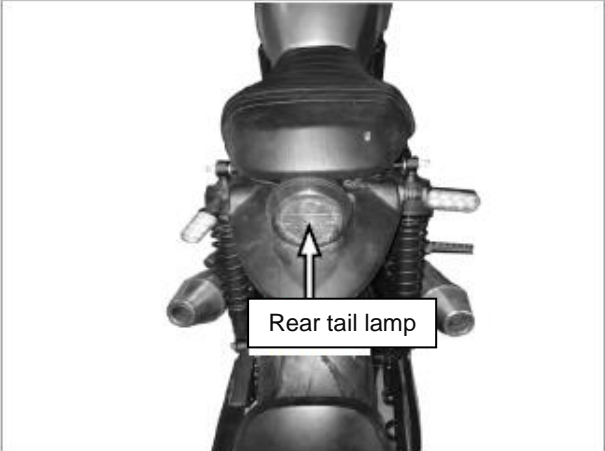
	<p>[2] Check whether the tail light is burnt out. When the tail lamp is burnt out, replace the same type of tail light.</p>
---	---

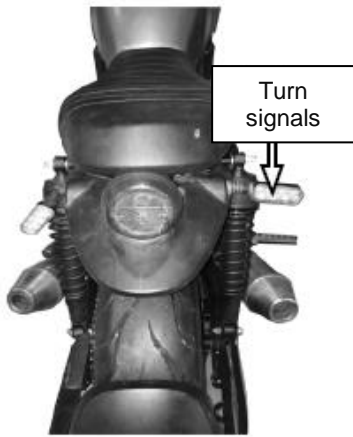

[3] Check whether the steering lamp is burnt out. If it is burnt out, replace the steering lamp of the same model.



[4] Check whether the indicator bulb of the instrument is burnt out. When the indicator bulb of the instrument is burnt out, replace the indicator bulb of the instrument.

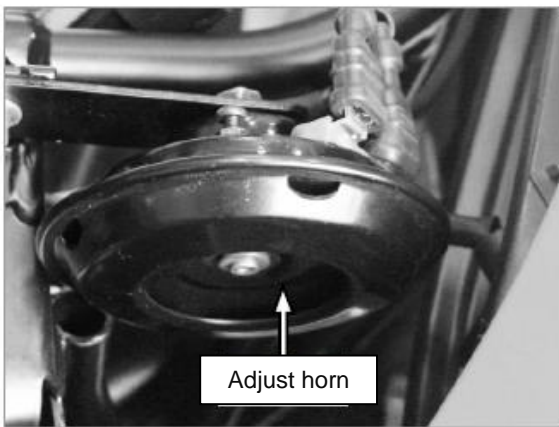

[5] When the sound of the electric horn is hoarse and the electric horn has no sound, adjust the volume of the electric horn according to the actual situation, or replace the electric horn of the same model.

III. Electricity part of the damage form, fault phenomenon and common maintenance methods are shown in table 4-3:

Table 4-3 Maintenance of power consumption

Part name	Damage form	Component failure phenomenon	Vehicle failure phenomenon	Maintenance method
Headlamp assembly	Improper beam adjustment	Headlamp beam too close or too far		Adjusting headlamp beam
	The filament of headlamp is burnt out	The filament of headlamp is burnt out	Headlamps are not on	To replace the headlamp bulb
Tail / brake lamp	Burnout of taillamp/brake filament	Burnout of taillamp/brake filament	Burnout of taillamp/brake filament	To replace the bulb of tail lamp/brake lamp
Turn signals	Filament burnout	Lamp filament of steering lamp is burnt out	The turn signal is not on	To replace the turn signal lamp bulb
Gear indicator	Filament burnout	The filament of the gear indicator lamp is burnt out	The gear indicator is not on	To replace the light bulb of shift position indicator lamp
Electric horn	Burned or damaged inside	Burned or damaged inside the klaxon	The klaxon does not sound or does not sound normally	To replace the klaxon

Chapter V Motorcycle Fault Diagnosis Procedure

Section 1 Engine Fault Diagnosis Procedures

Engine idle bad fault diagnosis procedures

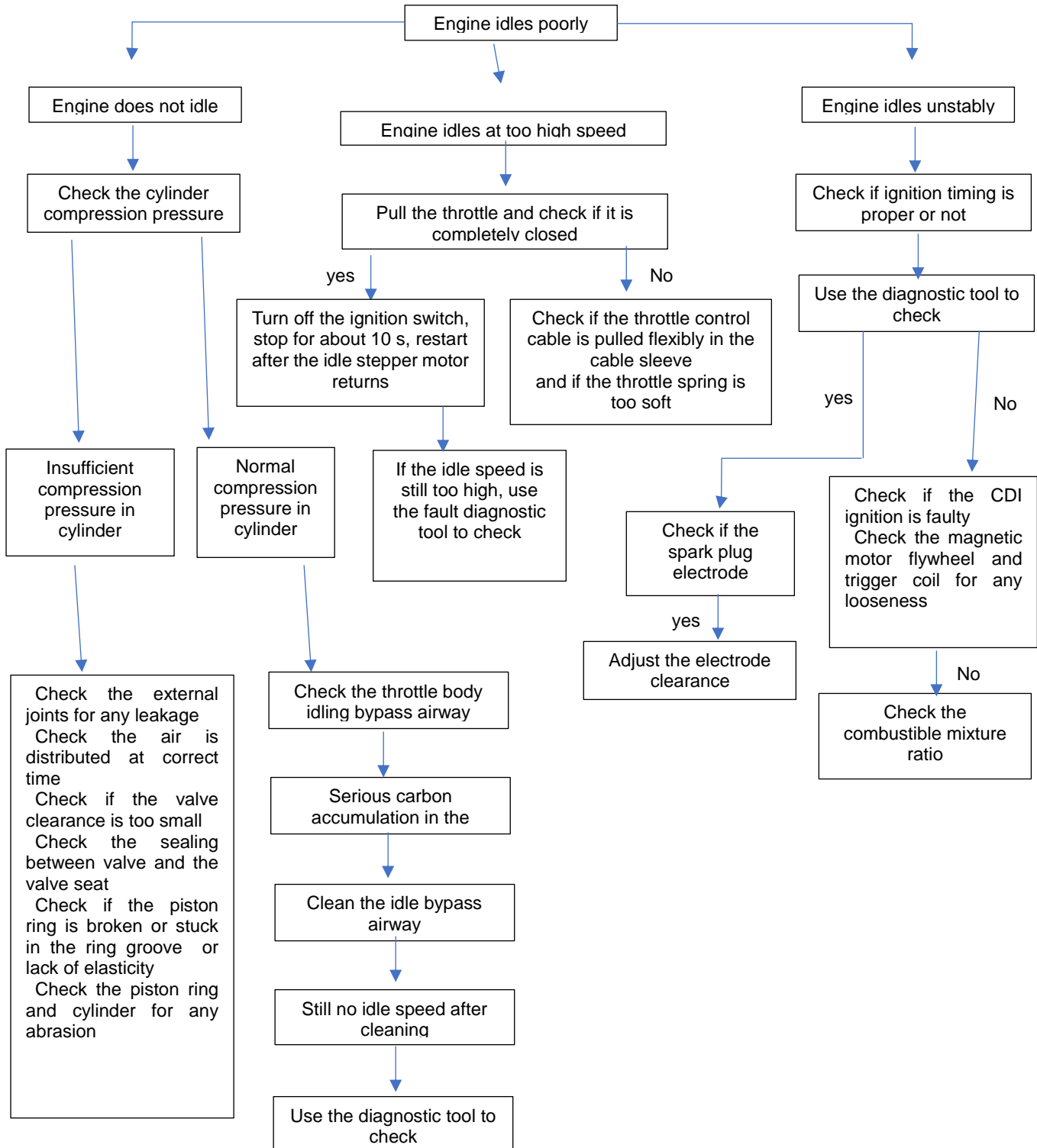

1.2 Fault diagnostic program for under-powered engine

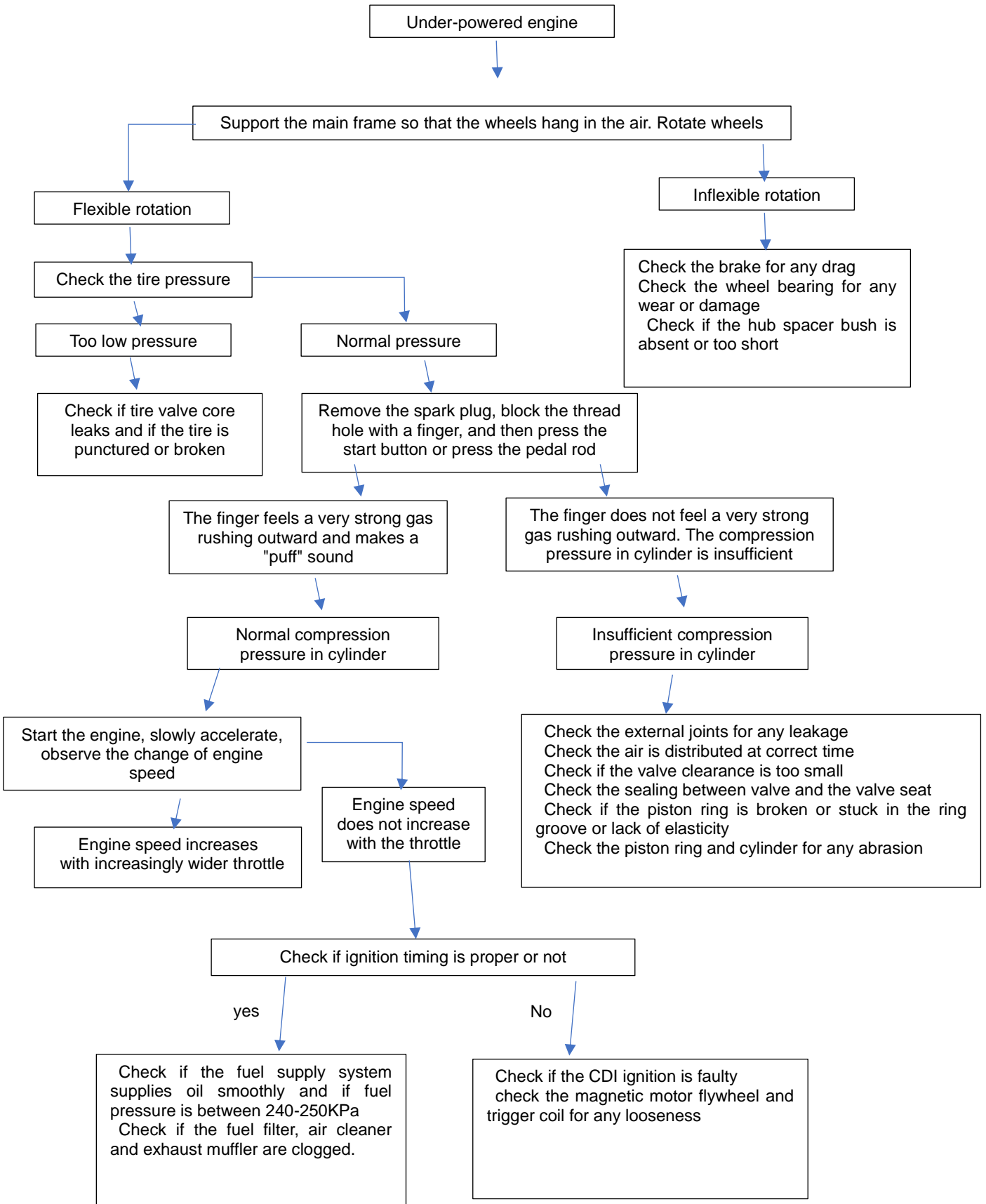

1.3 Fault diagnostic procedure for engine start failure or difficulty

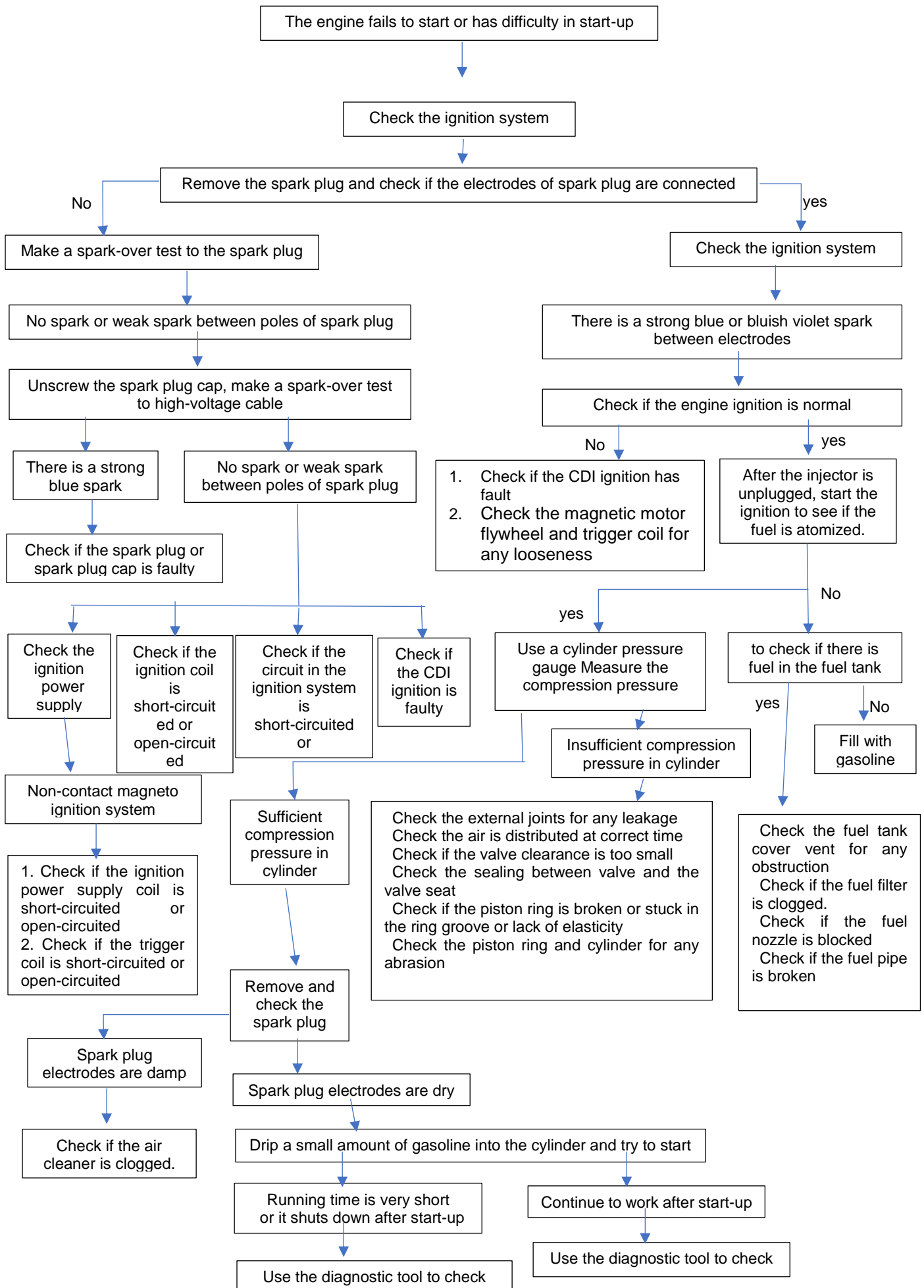

1.4 Fault diagnostic procedure for engine overheating

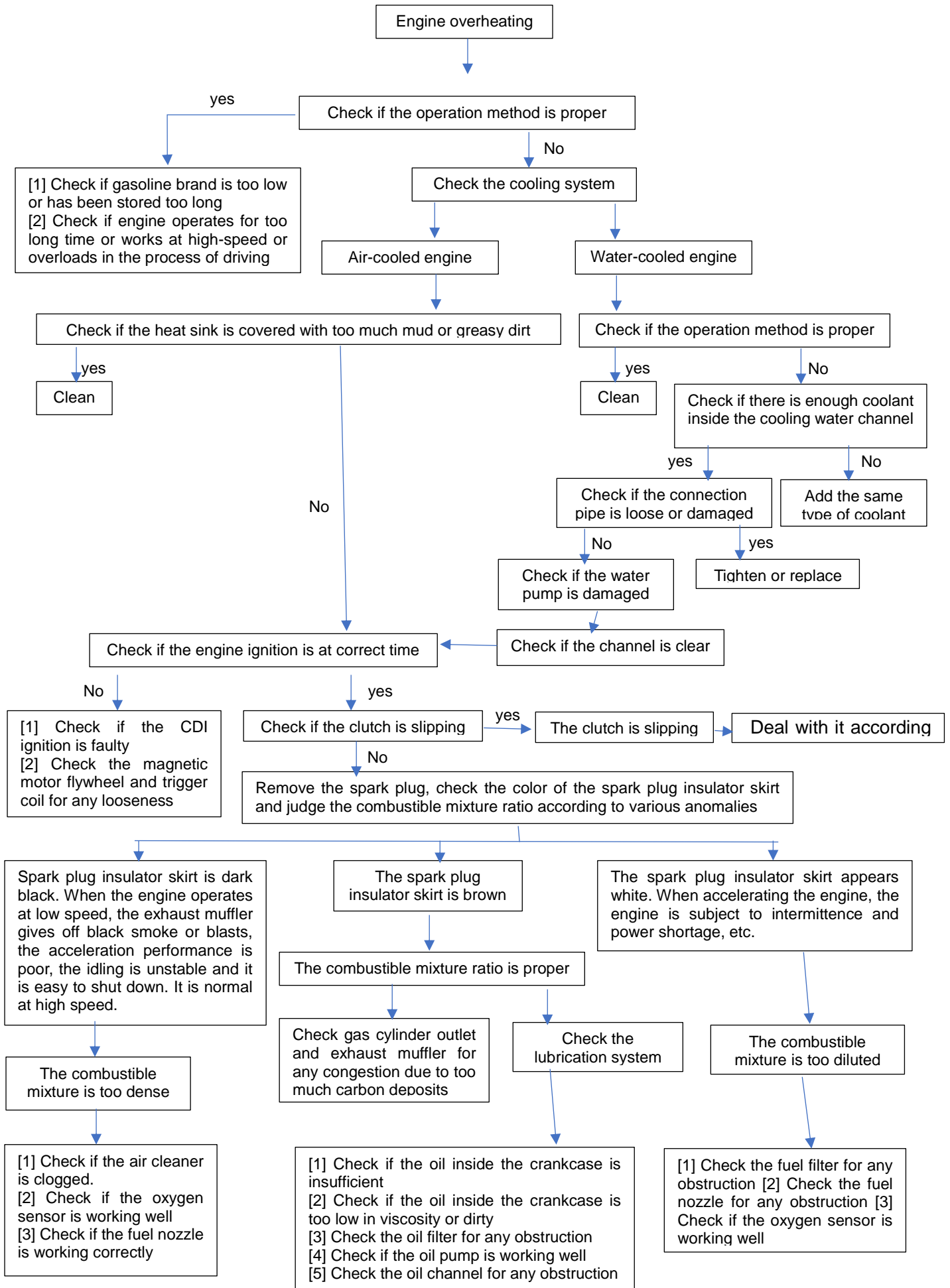

1.5 Fault diagnostic procedure for excessive fuel consumption

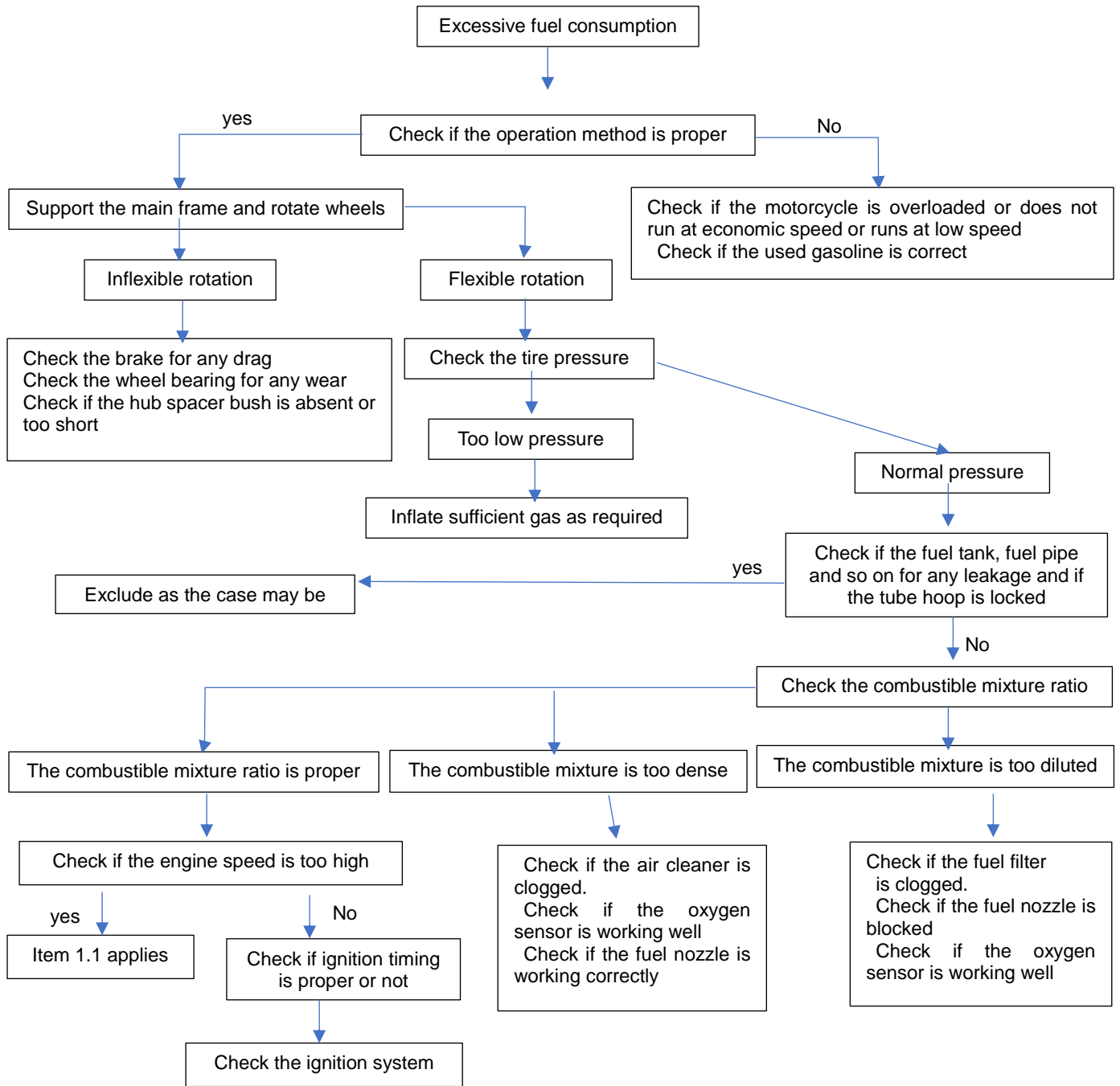

1.6 Fault diagnosis procedure for the exhaust muffler of four-stroke engine giving off blue-white smoke

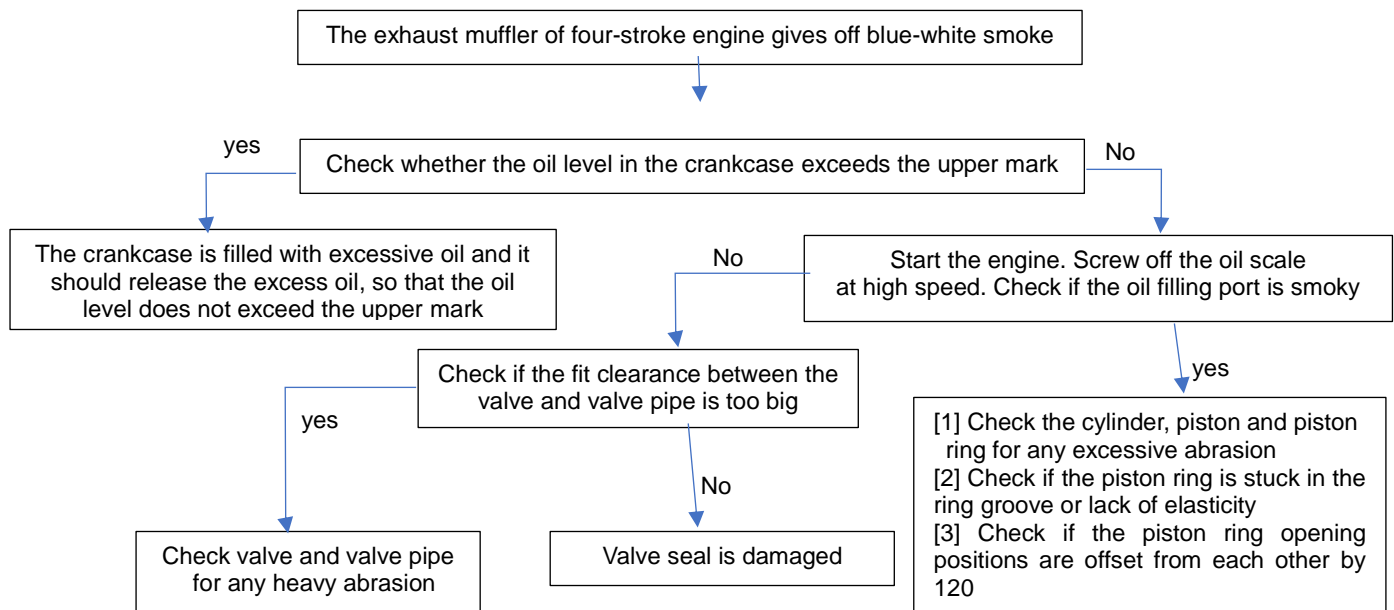

1.7 Fault diagnostic procedure for the gear shifting difficulties

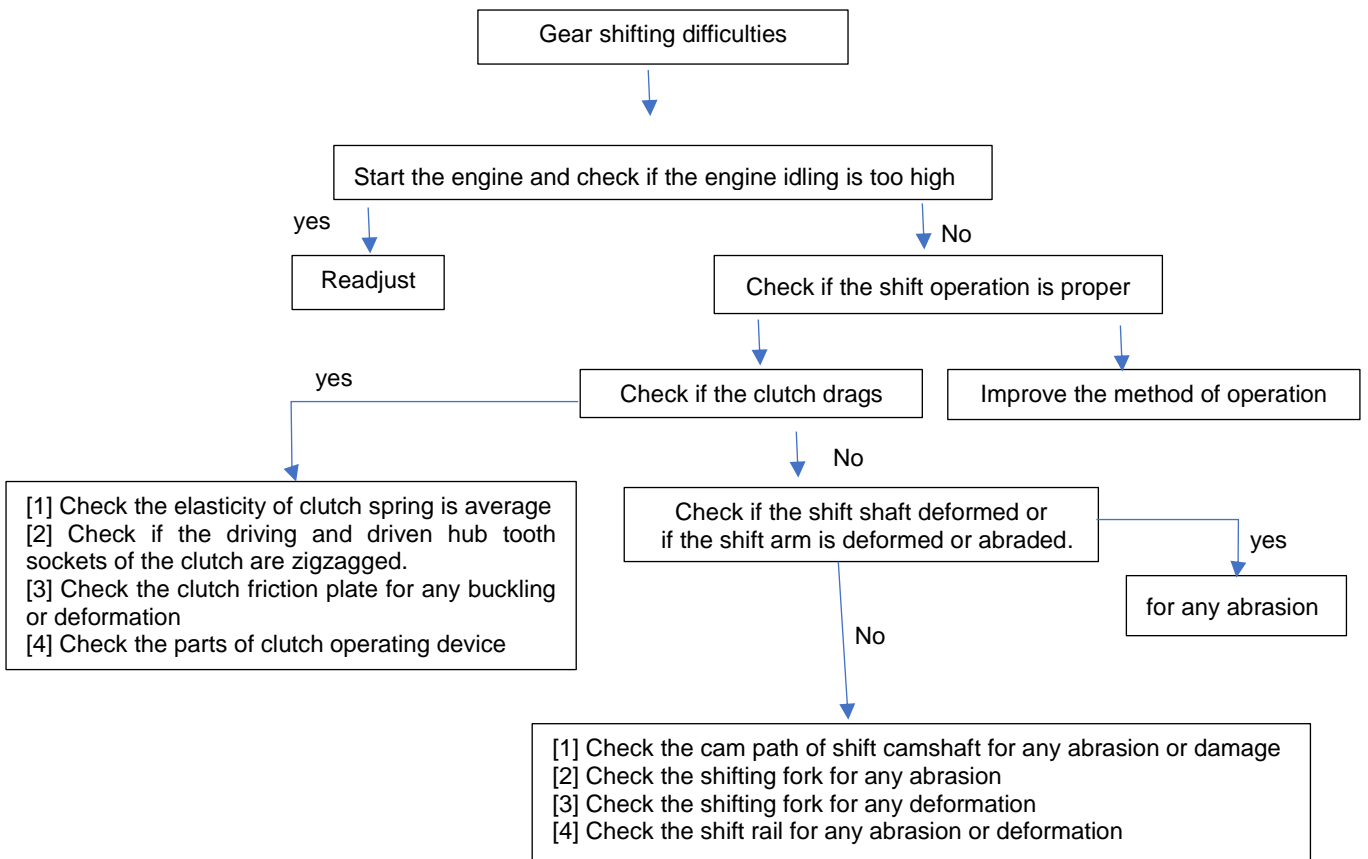

1.8 Fault diagnostic procedure for the gearshift groove-skipping

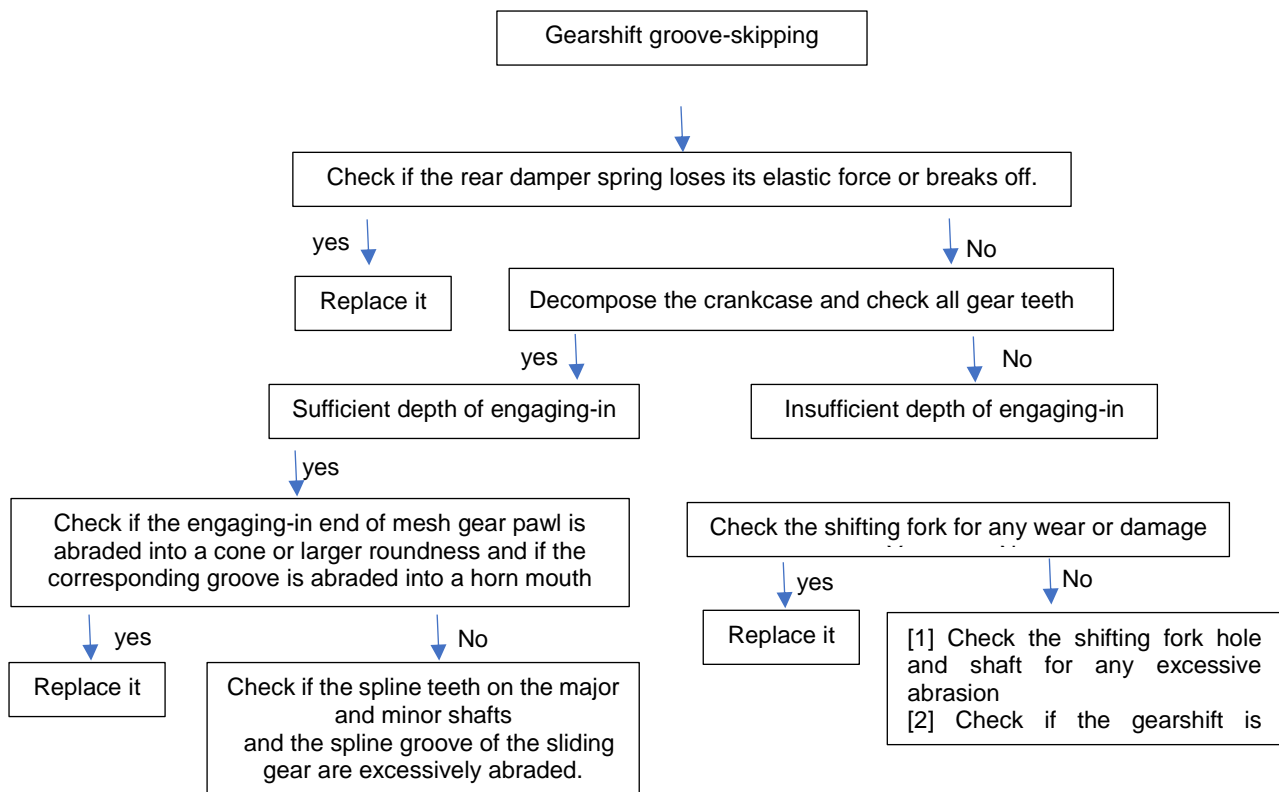

1.9 Fault diagnostic procedure for clutch slipping or dragging

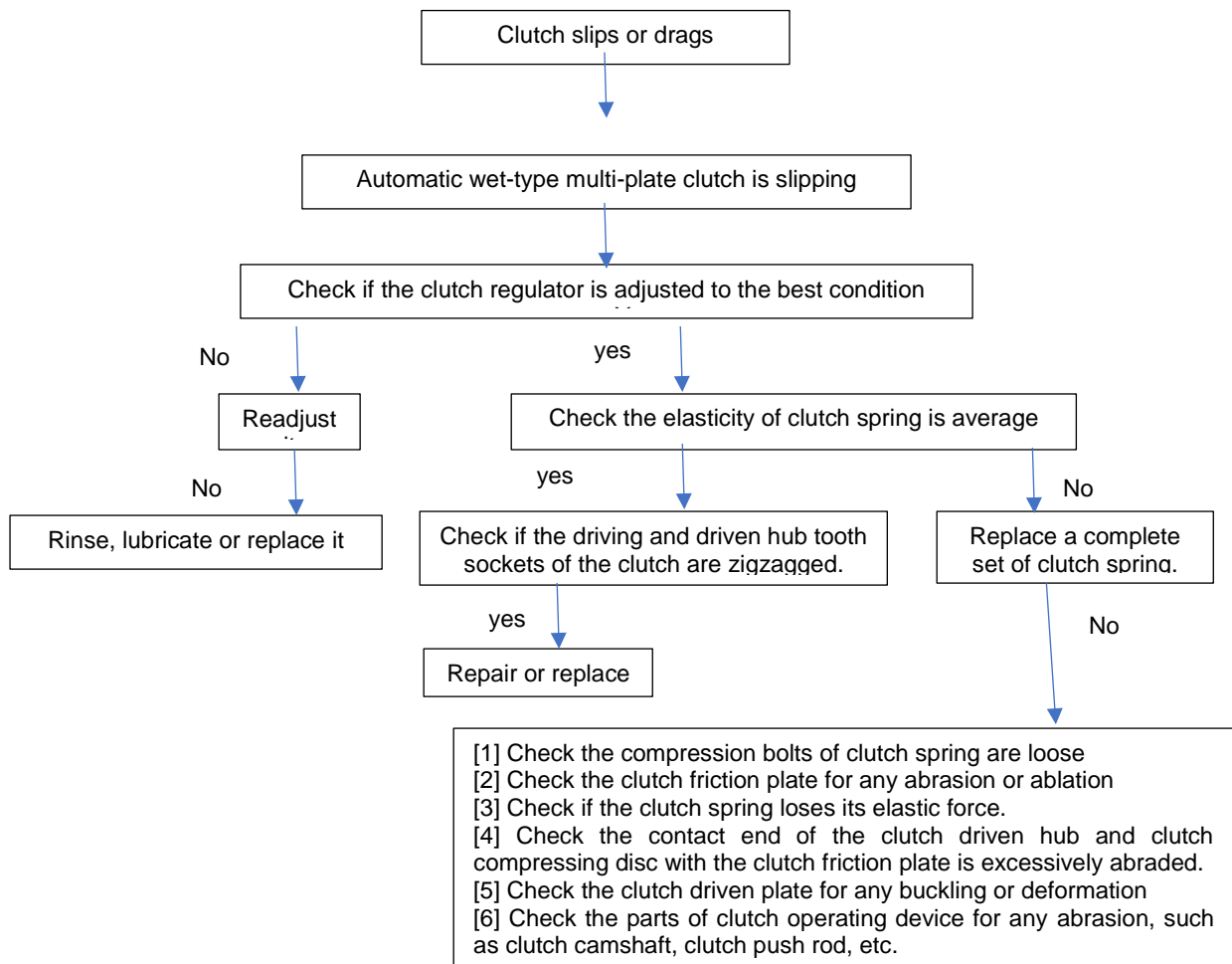

Section 2. Fault Diagnostic

2.1 Fault diagnostic procedure for no charging from storage battery

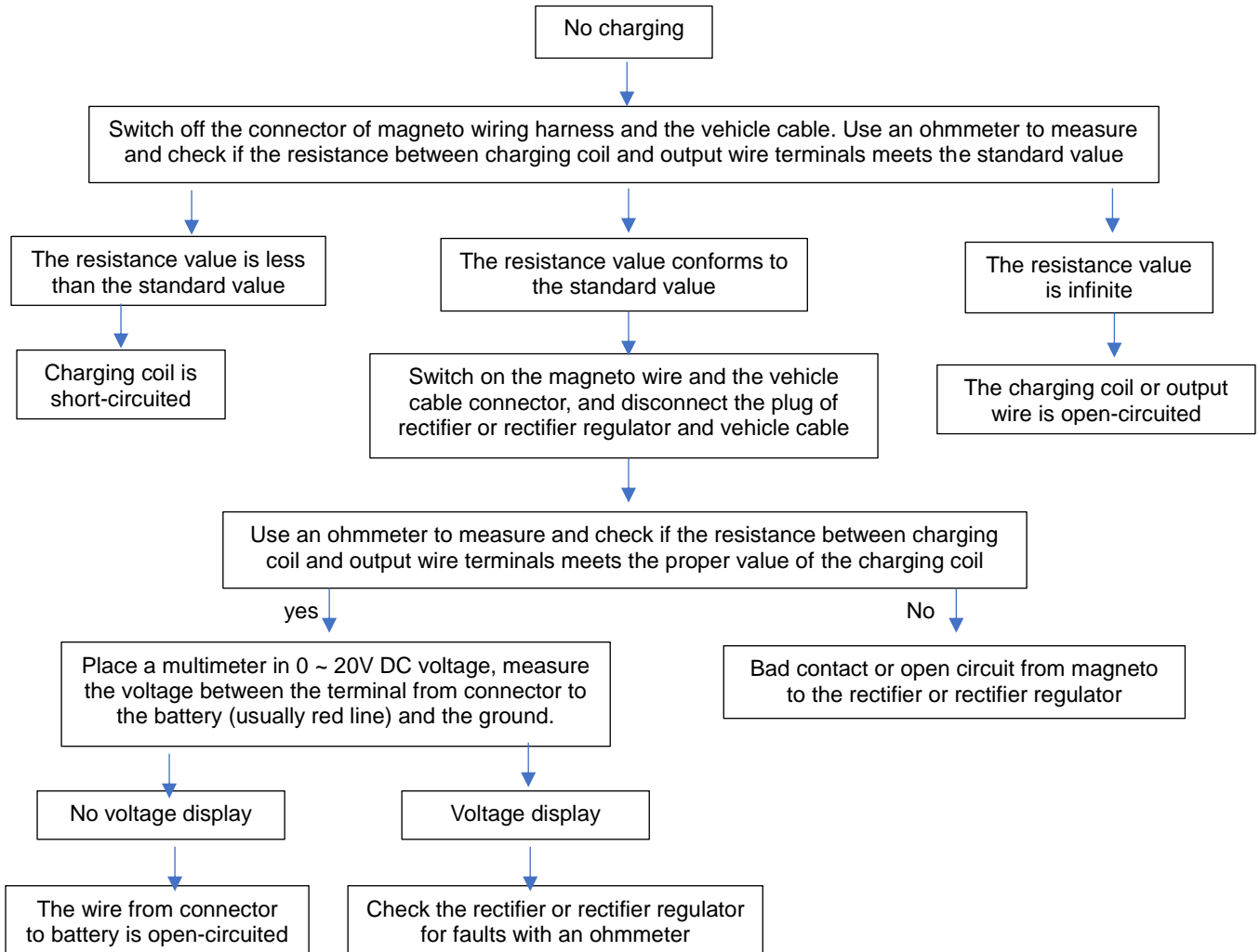

2.2 Fault diagnostic program for storage battery undercharging

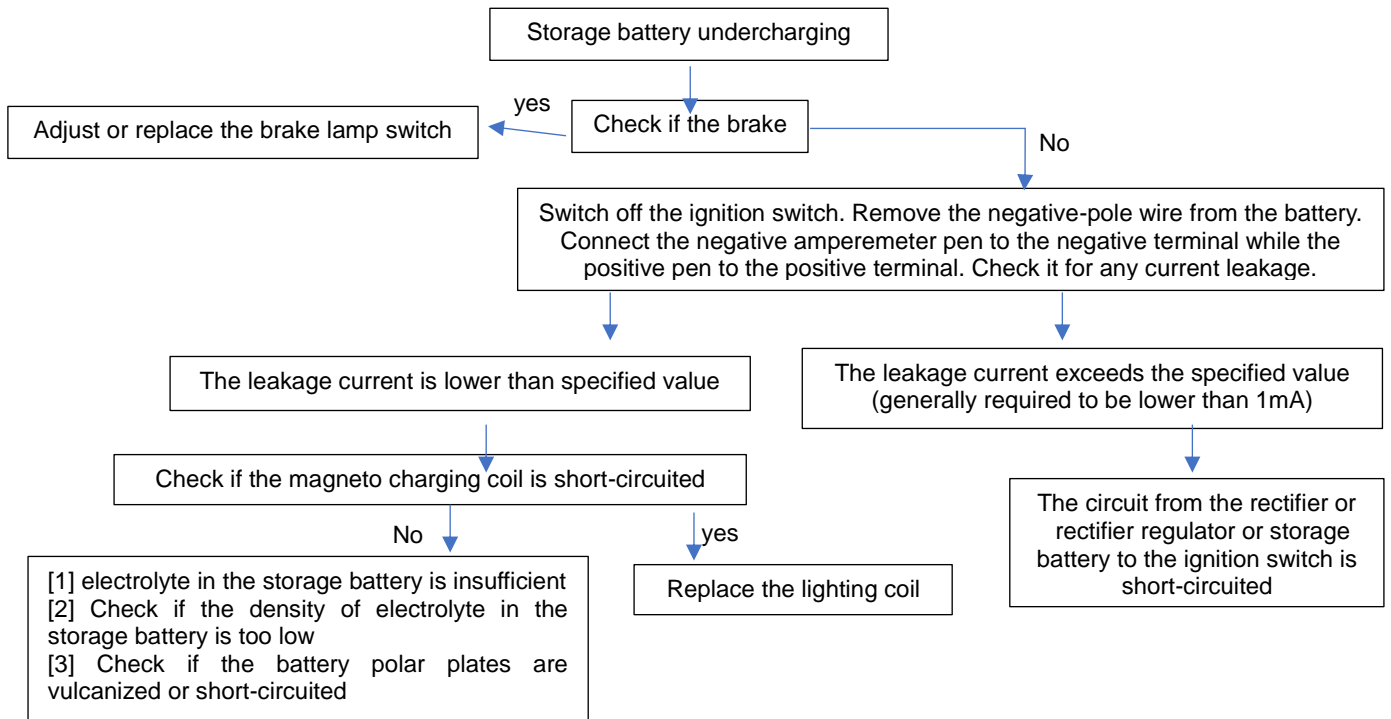

2.3 Fault diagnostic program for starting dynamo failure

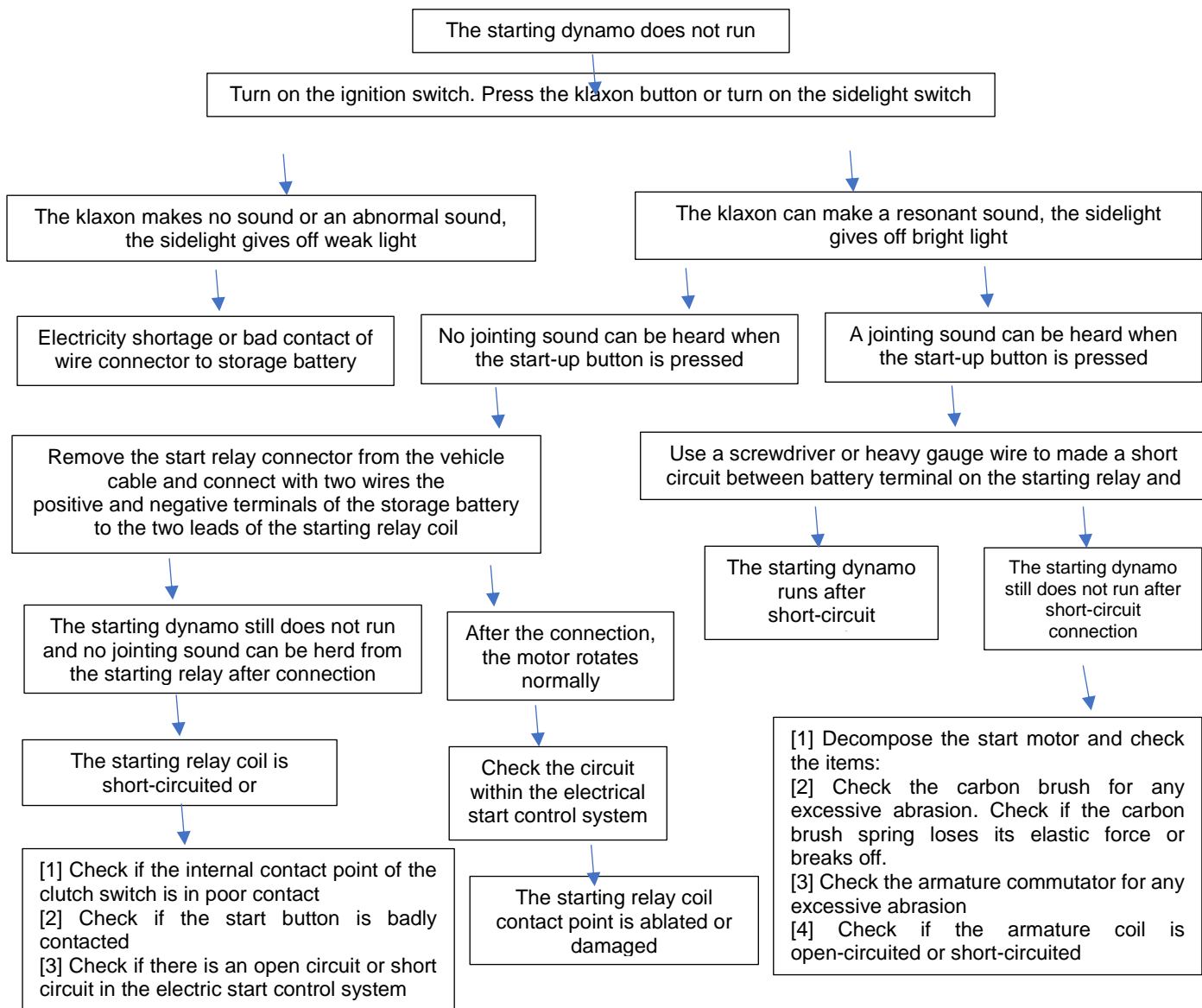

2.4 Fault diagnostic program for weak rotation of starting dynamo

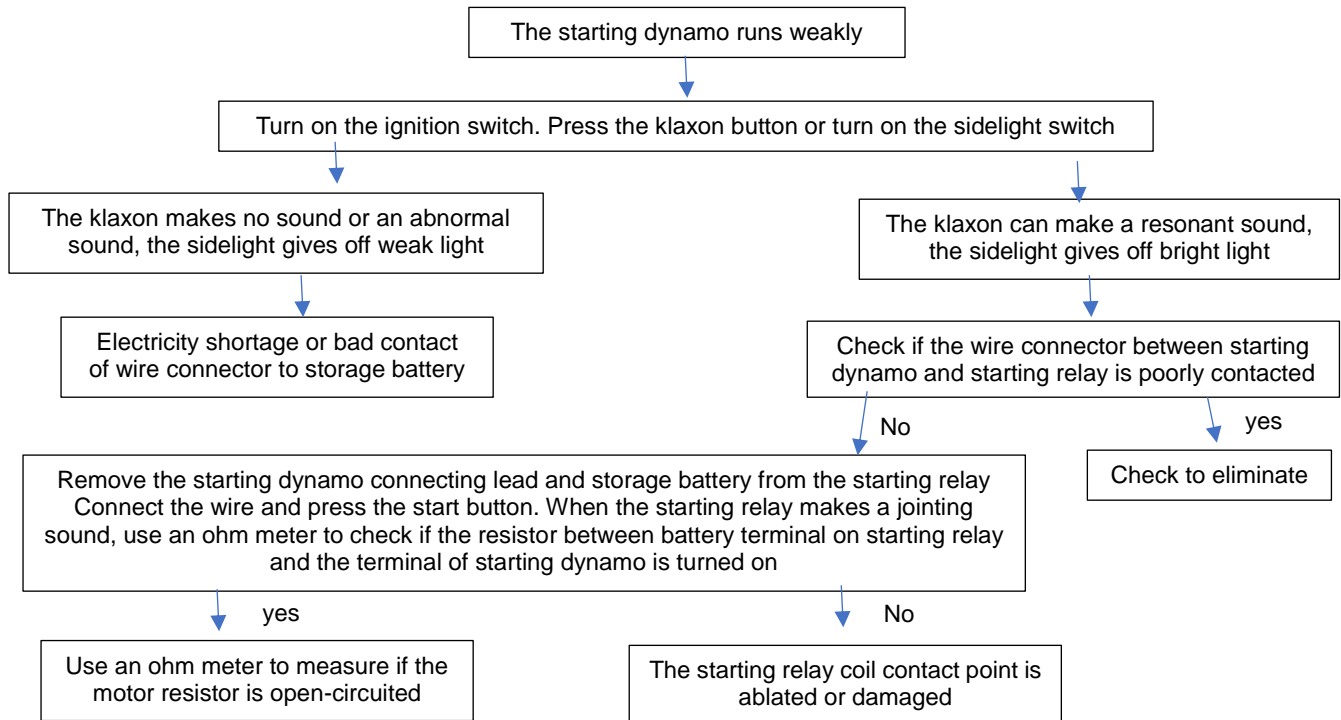

2.5 Fault diagnostic program for no illumination of all lighting lamps

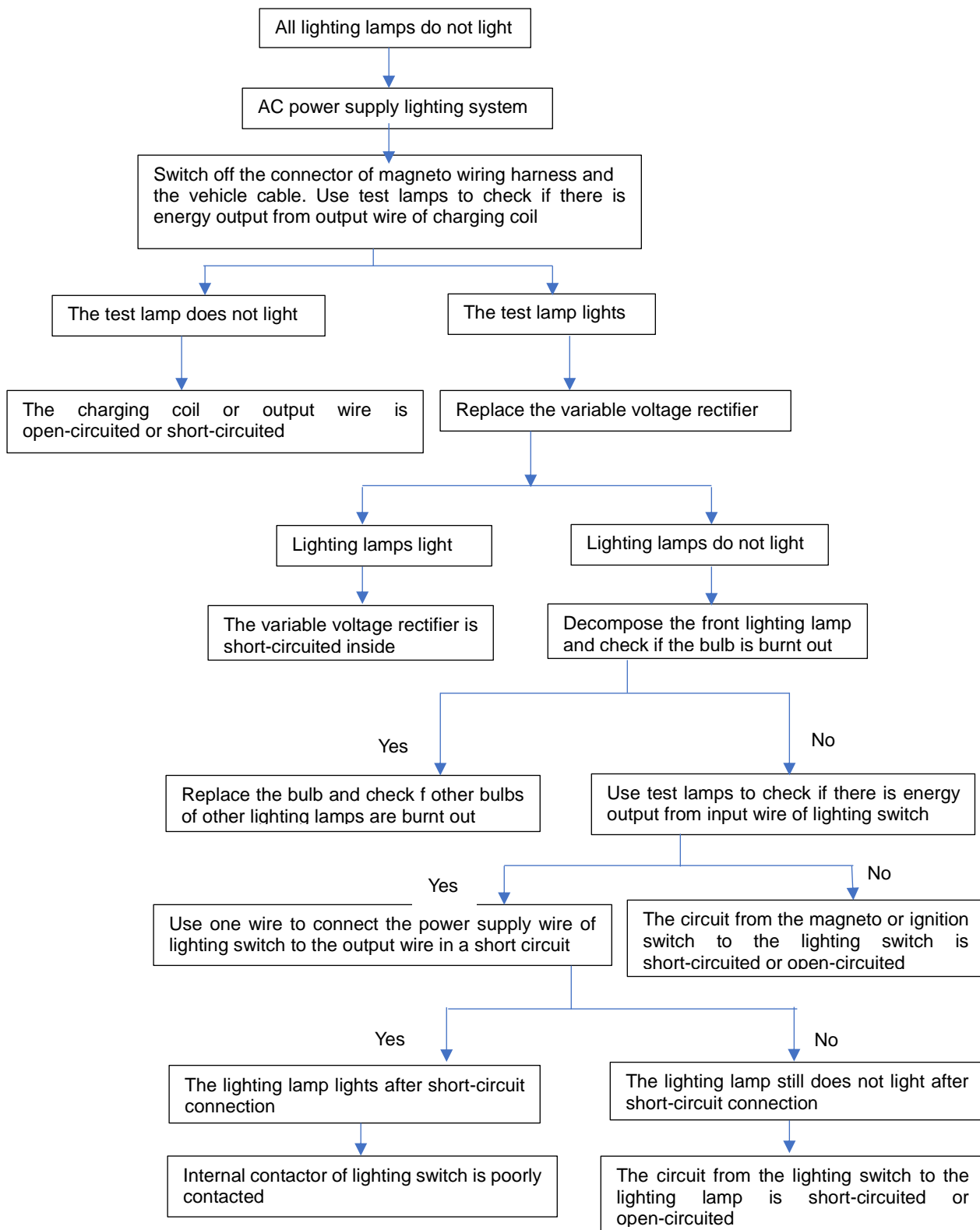

2.6 Fault diagnostic program for lighting lamp bulbs burning easily

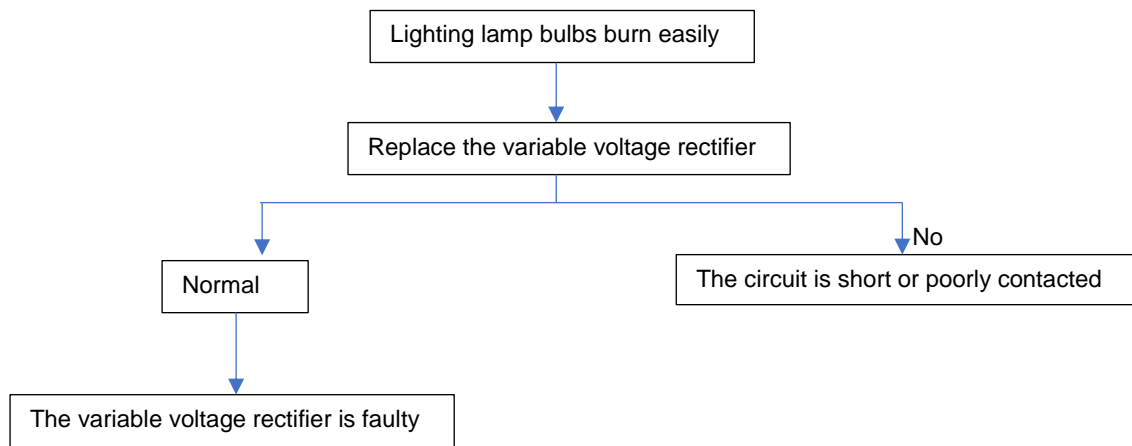

2.7 Fault diagnostic program for weak lighting of lighting lamps

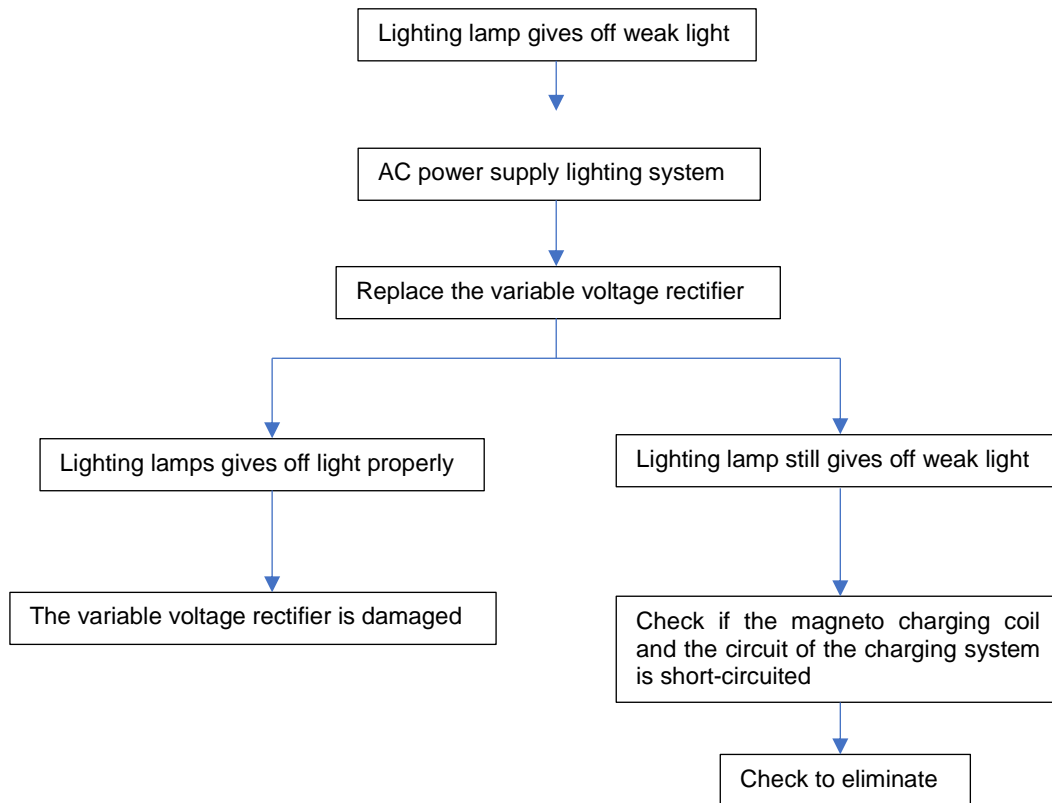

2.8 Fault diagnostic procedure for no lighting of sidelights

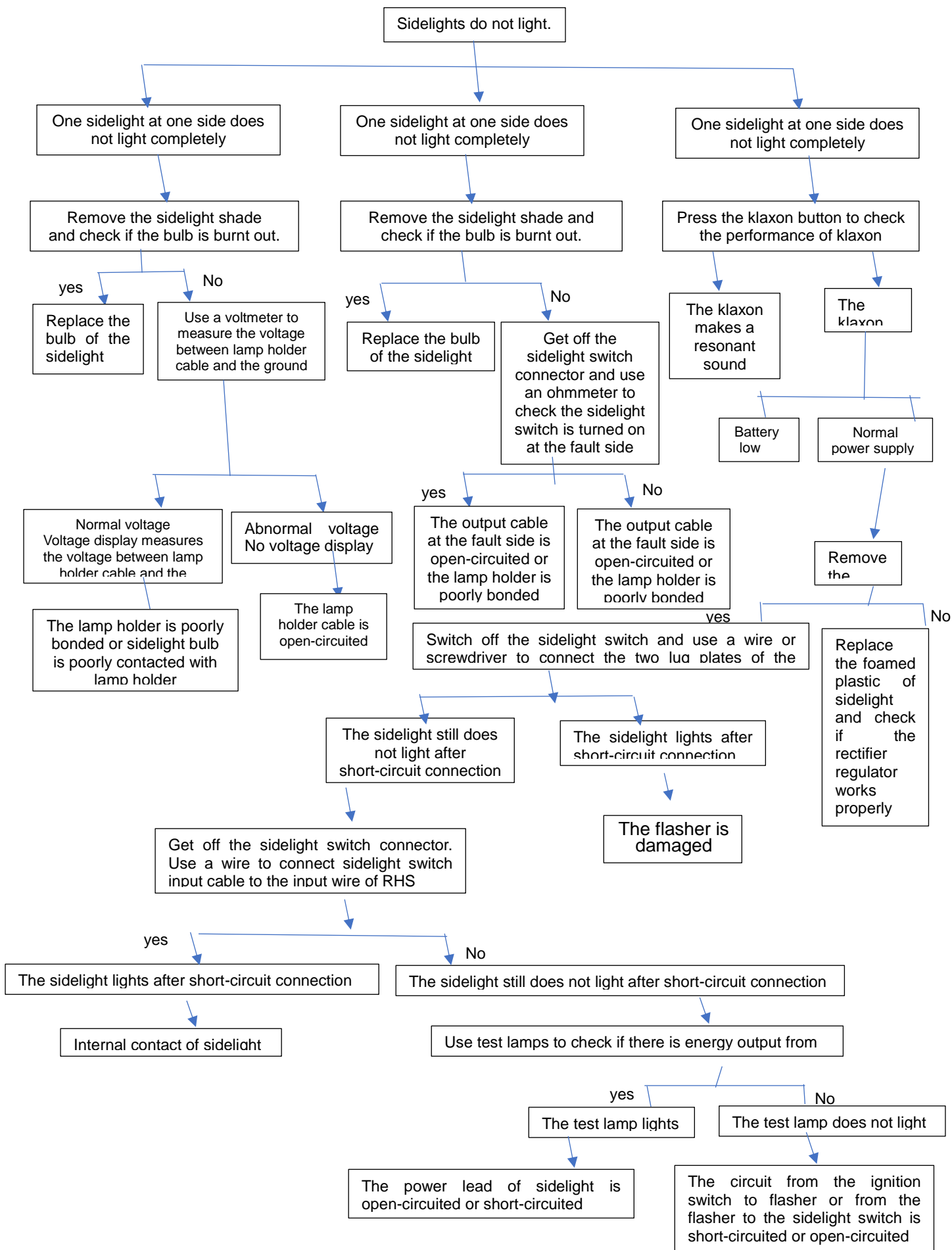

2.9 Fault diagnostic procedure for klaxon making no sound

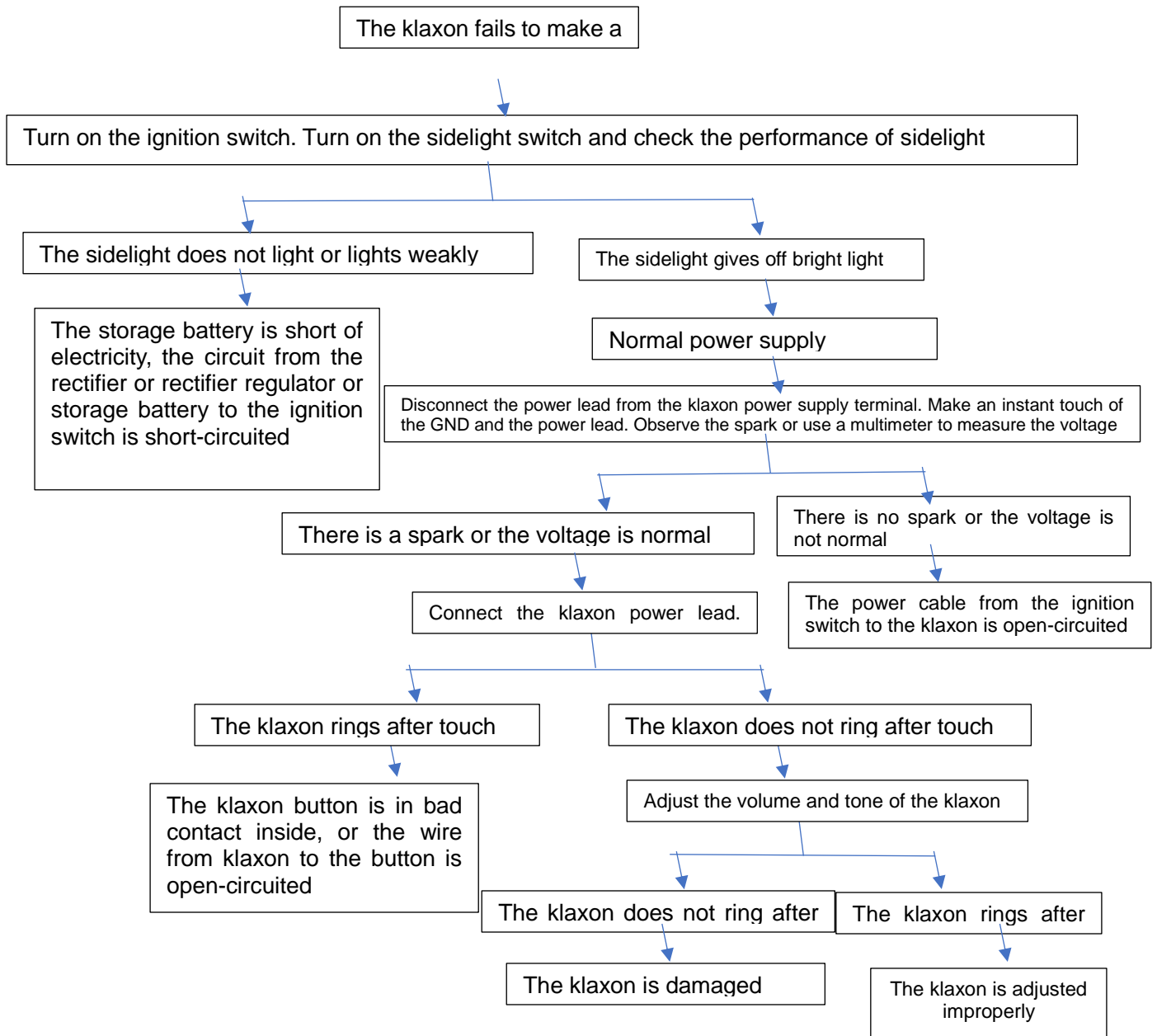

2.10 Fault diagnostic procedure for brake lamp lighting

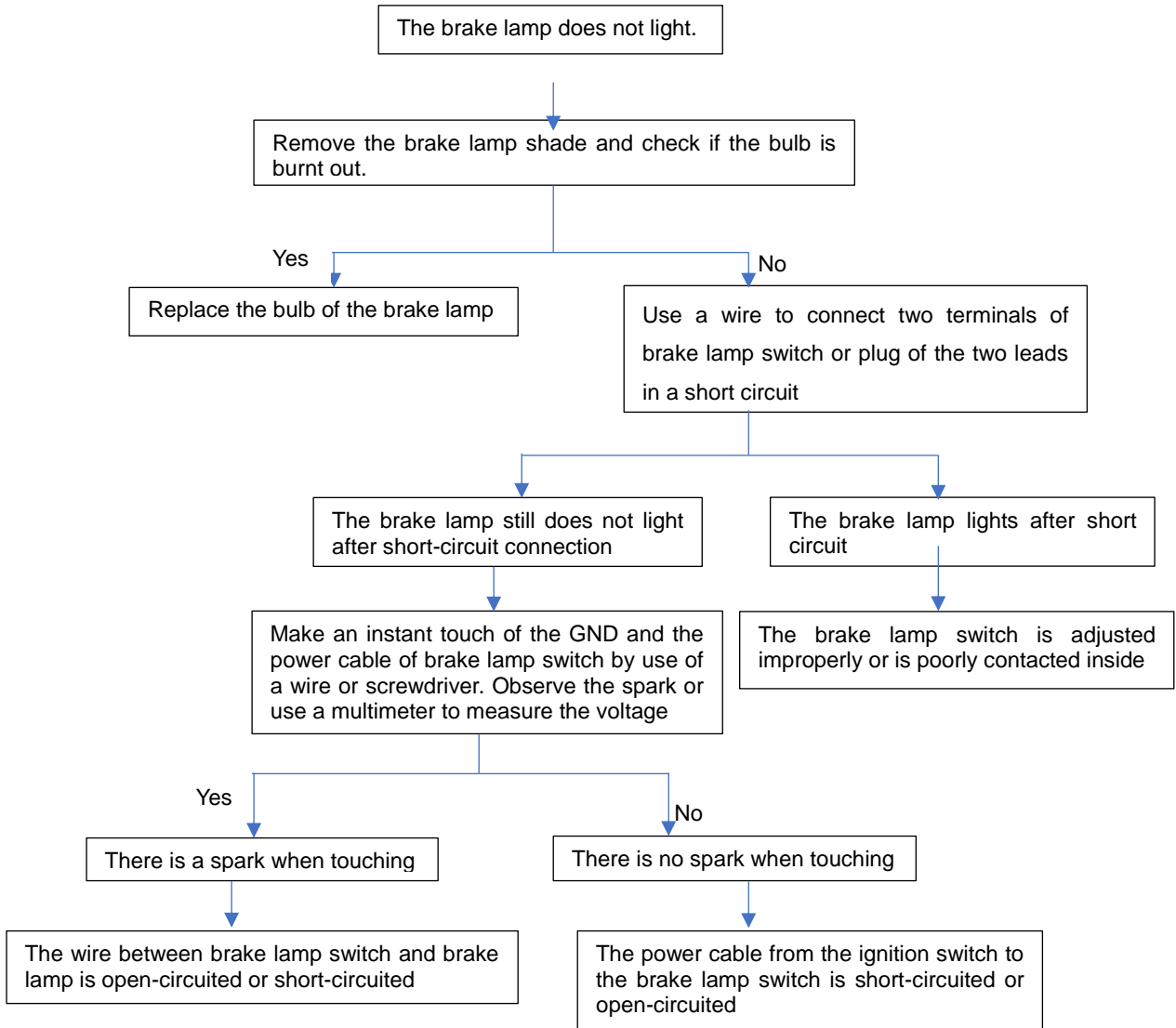

2.11 Fault diagnostic program for ignition system

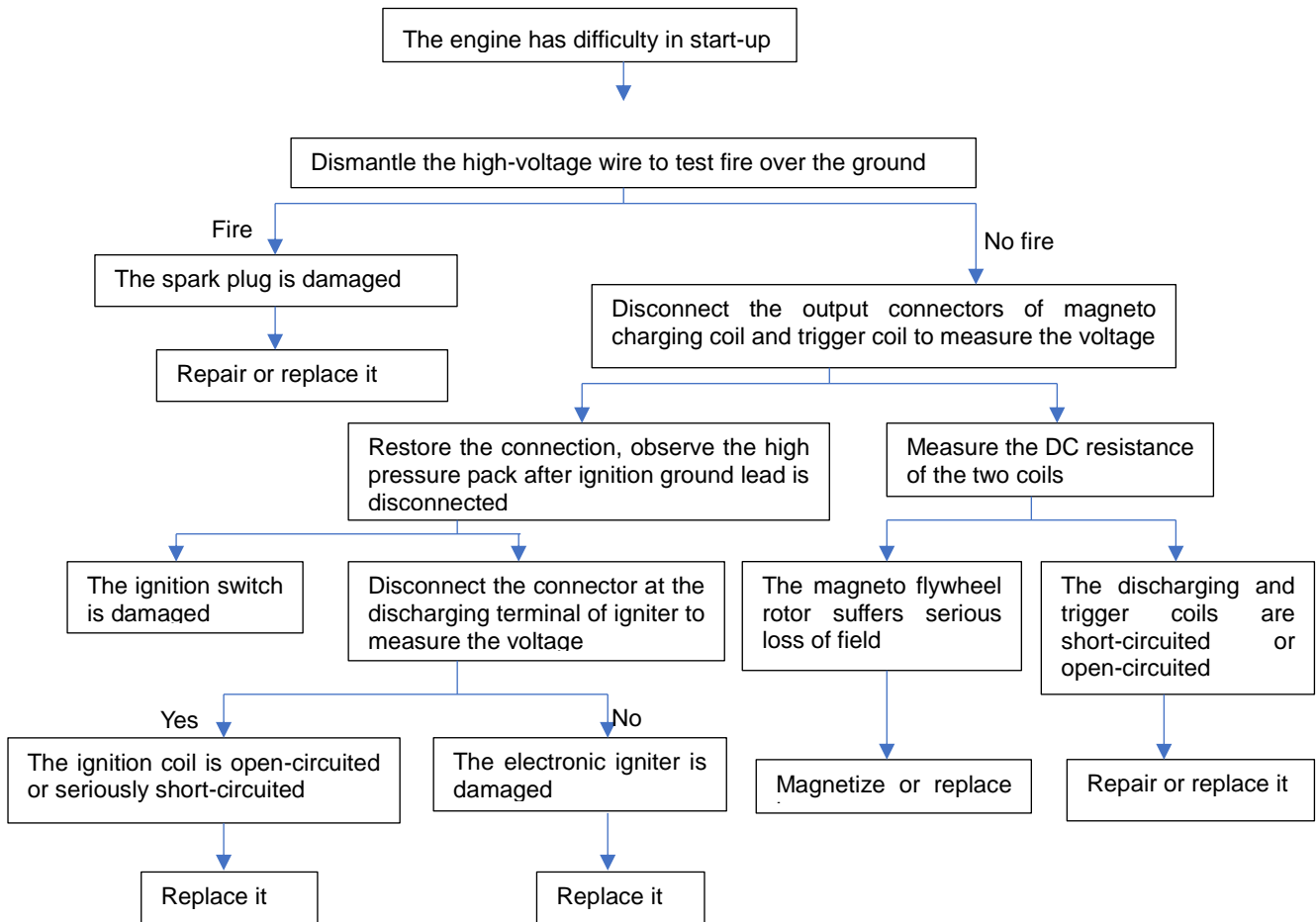

Appendix: Electrical Schematic Diagram

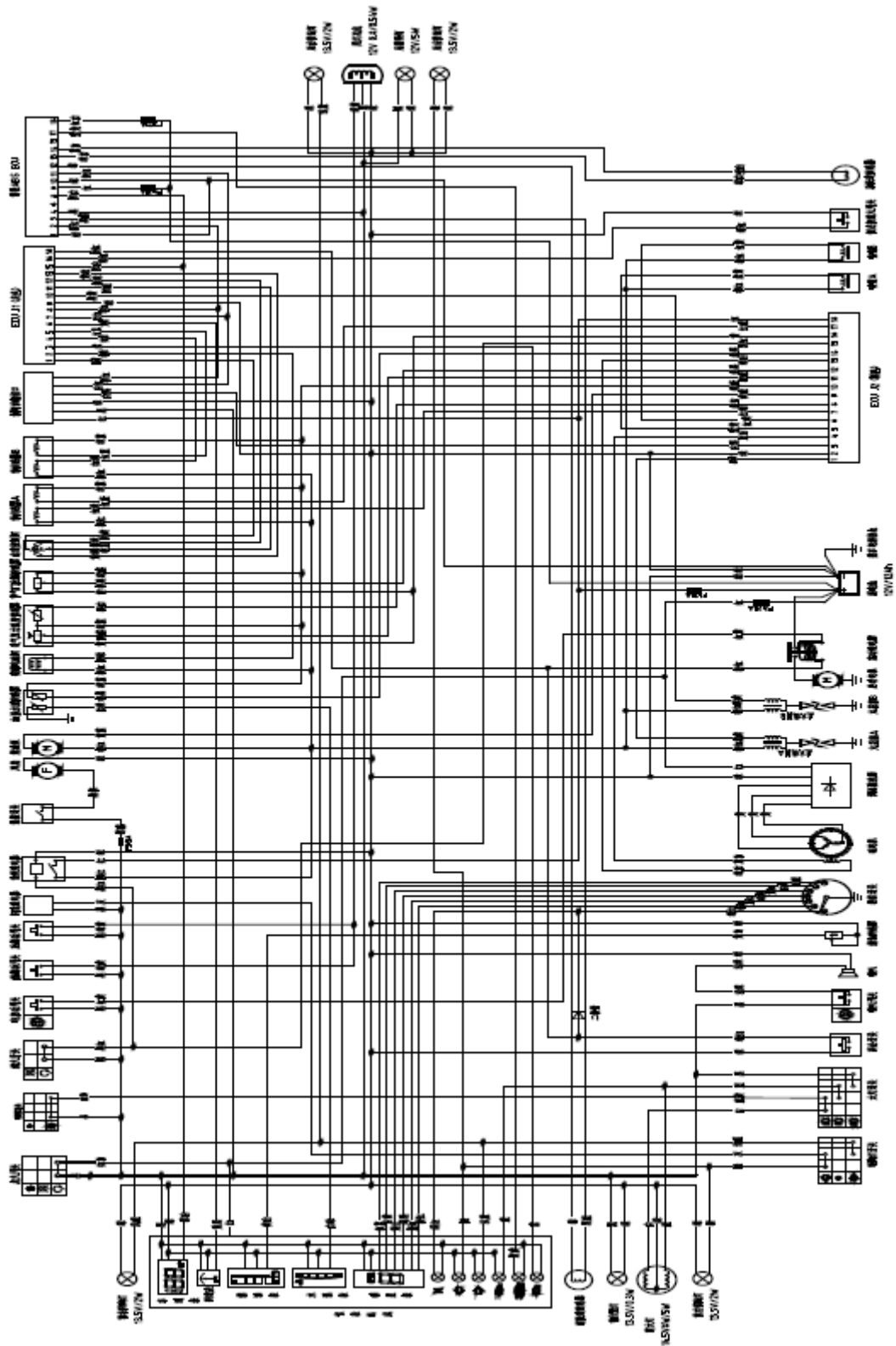

All rights reserved

160mm230mm

Format 160mm230mm

20197

First edition in July 2019

20197

First printing in July 2019